

Supplement of Biogeosciences, 14, 4279–4294, 2017  
<https://doi.org/10.5194/bg-14-4279-2017-supplement>  
© Author(s) 2017. This work is distributed under  
the Creative Commons Attribution 3.0 License.



*Supplement of*

## **Variability in above- and belowground carbon stocks in a Siberian larch watershed**

**Elizabeth E. Webb et al.**

*Correspondence to:* Susan M. Natali ([snatali@whrc.org](mailto:snatali@whrc.org))

The copyright of individual parts of the supplement might differ from the CC BY 3.0 License.

**Table S1.** Stand age characteristics of the Y4 watershed.

Site	N	Mean Age (yr)	Std Err	Min Age (yr)	Max Age (yr)	Median Age (yr)	Range (yr)
1	6	155.3	25.7	74	248	160.5	174
2	5	167.2	18.6	102	205	165	103
3	5	202.6	14.5	151	235	204	84
4	5	23.2	1.3	21	28	23	7
5	5	217.6	3.5	210	230	214	20
6	5	205.0	6.6	192	230	200	38
7	6	154.5	34.8	60	298	161.5	238
8	5	208.4	14.5	153	231	224	78
9	5	202.0	15.2	142	223	212	81
10	5	210.8	11.1	182	244	201	62
11	4	122.5	39.6	35	227	114	192
12	5	71.2	10.7	44	100	80	56
13	4	178.5	13.9	155	215	172	60
14	5	40.0	2.8	33	49	39	16
15	5	221.4	5.0	203	233	223	30
16	5	200.2	13.2	176	251	191	75
19	8	25.9	1.8	16	32	27	16

**Table S2.** Parameter values and standard errors of the soil C and thaw depth mixed effects models. Both soil C and thaw depth were log transformed. Moisture is gravimetric water content and in the top 10 cm of soil.

Model	Coefficient	Parameter value (SE)	p-value
Soil Carbon	Intercept	7.4900 (0.16)	
	Percent Moss	-0.0099 (0.0037)	0.0111
	Percent Lichen	-0.0076 (0.0034)	0.0333
	Moisture	0.0260 (0.0065)	0.0003
Thaw Depth	Intercept	3.7200 (0.1)	
	Stand Age	-0.0029 (0.0006)	<0.0001

**Table S3:** Unaggregated soil characteristics and C density for sampling sites in the Y4 watershed. BD: bulk density; GWC: gravimetric water content; VWC: volumetric water content; SOM: soil organic matter content; mineral and organic soil pools were normalized to 10 cm depths. Mineral soil depths are depth sampled from the bottom of the organic layer. Meter represents the sampling location along the 20-m-long plot.

Site	Plot	Meter	Organic/Mineral	Core depth (cm)	BD (g cm <sup>3</sup> )	GWC (%)	VWC (%)	SOM(%)	Mineral soil C (g C m <sup>2</sup> )	Organic soil C (g C m <sup>2</sup> )	Total soil C; 10 cm (g C m <sup>2</sup> )	Root C; 10 cm (g C m <sup>2</sup> )	Total belowground C; 10 cm (g C m <sup>2</sup> )
1	1	0	O	12	0.03	233.7	6.2	42.1	-	1116	1116	289	1405
1	1	0	M	3	0.23	132.6	30.4	17.9	-	-	-	0	-
1	1	20	O	5	0.18	86.6	15.3	21.8	-	3851	3085	16	3101
1	1	20	M	16	1.27	28.7	36.3	1.8	2319	-	-	0	-
1	2	0	O	9	0.06	143.5	8.7	38.3	-	2322	2190	0	2190
1	2	0	M	16	0.55	26.6	14.6	1.8	998	-	-	0	-
1	2	20	O	9	0.05	253.5	12.0	44.3	-	2094	2116	345	2461
1	2	20	M	8	0.44	48.4	21.2	5.3	2311	-	-	0	-
1	3	0	O	6	0.08	158.7	12.9	34.2	-	2773	2308	34	2341
1	3	0	M	13	0.35	51.6	18.0	4.6	1609	-	-	0	-
1	3	20	O	6	0.08	317.3	24.5	44.7	-	3452	3246	135	3381
1	3	20	M	14	0.30	100.7	30.4	9.7	2937	-	-	0	-
2	1	0	O	8	0.09	110.4	9.9	20.2	-	1813	1591	368	1959
2	1	0	M	19	0.58	21.6	12.6	1.2	702	-	-	0	-
2	1	20	O	13	0.02	309.9	5.8	46.1	-	860	860	65	925
2	2	0	O	11	0.02	200.9	4.8	41.2	-	991	991	92	1083
2	2	0	M	12	0.74	26.9	19.8	1.7	1226	-	-	0	-
2	2	20	O	13	0.04	153.3	6.2	33.4	-	1353	1353	0	1353
2	2	20	M	11	0.58	39.5	22.8	3.9	2264	-	-	0	-
2	3	0	O	10	0.05	231.5	11.5	46.9	-	2327	2327	39	2366
2	3	0	M	8	0.54	53.9	28.9	3.2	1716	-	-	0	-
2	3	20	O	16	0.02	216.8	4.0	42.3	-	775	775	19	794
2	3	20	M	21	0.78	27.7	21.7	1.8	1397	-	-	0	-
3	1	0	O	10	0.07	86.8	5.9	28.3	-	1934	1934	25	1959
3	1	0	M	16	0.76	20.4	15.5	1.6	1216	-	-	0	-
3	1	20	O	11	0.04	94.3	3.5	24.2	-	902	902	34	936
3	1	20	M	9	0.39	43.7	16.9	4.3	1652	-	-	0	-
3	2	0	O	11	0.10	64.2	6.3	24.2	-	2378	2378	273	2650

Site	Plot	Meter	Organic/Mineral	Core depth (cm)	BD (g cm <sup>3</sup> )	GWC (%)	VWC (%)	SOM(%)	Mineral soil C (g C m <sup>2</sup> )	Organic soil C (g C m <sup>2</sup> )	Total soil C; 10 cm (g C m <sup>2</sup> )	Root C; 10 cm (g C m <sup>2</sup> )	Total belowground C; 10 cm (g C m <sup>2</sup> )
3	2	0	M	12	1.04	22.9	23.9	1.8	1855	-	-	0	-
3	2	20	O	12	0.03	176.3	4.8	35.8	-	980	980	69	1049
3	3	0	O	10	0.06	117.3	6.9	35.2	-	2077	2077	159	2236
3	3	0	M	15	0.55	34.3	18.7	3.1	1669	-	-	0	-
3	3	20	O	9	0.08	80.8	6.8	34.5	-	2909	2696	90	2786
3	3	20	M	12	0.75	24.1	18.0	1.0	780	-	-	0	-
4	1	0	O	9	0.15	44.9	6.6	12.3	-	1803	1766	35	1801
4	1	0	M	15	0.85	17.5	14.9	1.7	1435	-	-	0	-
4	1	20	O	8	0.03	181.8	5.6	33.9	-	1046	1286	326	1612
4	1	20	M	6	0.48	43.5	20.9	4.7	2244	-	-	0	-
4	2	0	O	1	0.42	63.4	26.5	21.0	-	5189	5189	15	5205
4	2	0	O	7	0.23	30.5	7.0	20.9	-	-	-	0	-
4	2	20	O	10	0.02	131.0	2.4	36.4	-	667	667	15	682
4	3	0	O	8	0.05	192.4	8.9	34.8	-	1615	3047	625	3672
4	3	0	M	3	0.72	96.7	69.6	12.2	-	-	-	0	-
4	3	20	M	3	0.03	96.6	3.1	18.4	593	-	6248	0	6248
4	3	20	M	23	0.63	50.6	31.8	6.3	3974	-	-	0	-
5	1	0	O	7	0.16	162.2	26.1	29.8	-	4805	3700	678	4378
5	1	0	M	11	1.30	19.2	25.0	0.9	1123	-	-	0	-
5	1	20	O	12	0.07	283.6	21.3	49.1	-	3680	3680	221	3902
5	1	20	M	11	0.87	32.4	28.3	2.4	2140	-	-	0	-
5	2	0	O	6	0.07	236.6	17.2	42.1	-	3063	2402	191	2594
5	2	0	M	12	1.09	25.3	27.5	1.3	1411	-	-	0	-
5	2	20	O	10	0.06	172.0	10.6	37.6	-	2313	2313	967	3280
5	2	20	M	13	0.90	27.0	24.2	1.9	1711	-	-	0	-
5	3	20	O	5	0.23	246.9	56.2	37.4	-	8498	4983	210	5193
5	3	20	M	11	0.96	24.2	23.1	1.5	1468	-	-	0	-
6	1	0	O	10	0.05	213.8	9.8	44.4	-	2032	2032	23	2055
6	1	20	O	6	0.07	202.1	15.0	38.8	-	2879	3024	30	3054
6	1	20	M	6	0.50	53.3	26.5	6.5	3242	-	-	0	-
6	2	0	O	9	0.11	172.4	18.9	36.8	-	4025	3937	437	4373
6	2	0	M	12	0.54	44.3	23.9	5.8	3143	-	-	0	-

Site	Plot	Meter	Organic/Mineral	Core depth (cm)	BD (g cm <sup>3</sup> )	GWC (%)	VWC (%)	SOM(%)	Mineral soil C (g C m <sup>2</sup> )	Organic soil C (g C m <sup>2</sup> )	Total soil C; 10 cm (g C m <sup>2</sup> )	Root C; 10 cm (g C m <sup>2</sup> )	Total belowground C; 10 cm (g C m <sup>2</sup> )
6	2	20	O	9	0.30	87.6	26.4	25.7	-	7728	7138	694	7832
6	2	20	M	12	0.65	23.6	15.4	2.8	1827	-	-	0	-
6	3	0	O	9	0.11	207.2	22.3	42.9	-	4614	4270	183	4453
6	3	0	M	12	0.78	23.5	18.3	1.5	1177	-	-	0	-
6	3	20	O	13	0.04	209.1	8.6	45.2	-	1860	1860	13	1873
7	1	0	O	9	0.05	314.2	14.3	36.7	-	1674	1756	13	1770
7	1	0	M	9	1.04	31.9	33.3	2.4	2494	-	-	0	-
7	1	20	O	14	0.02	369.0	5.6	48.4	-	733	733	19	752
7	2	0	O	12	0.02	569.8	8.8	47.5	-	738	738	0	738
7	2	20	O	11	0.02	270.2	4.8	40.0	-	714	714	56	770
7	2	20	M	20	1.08	21.7	23.5	1.3	1378	-	-	0	-
7	3	0	O	10	0.03	335.8	10.2	46.9	-	1422	1422	37	1459
7	3	0	M	15	0.53	53.7	28.4	5.8	3043	-	-	0	-
7	3	20	O	11	0.03	232.1	7.5	46.6	-	1503	1503	136	1639
7	3	20	M	7	0.37	66.8	24.7	6.3	2316	-	-	0	-
8	1	0	O	14	0.03	367.5	12.5	45.8	-	1564	1564	13	1577
8	1	20	O	12	0.02	427.7	10.0	47.2	-	1103	1103	54	1157
8	2	0	O	7	0.03	254.5	8.6	47.3	-	1589	2234	101	2334
8	2	0	M	15	0.70	52.5	37.0	5.3	3737	-	-	0	-
8	2	20	O	13	0.03	289.0	7.3	48.2	-	1217	1217	14	1232
8	2	20	M	16	0.49	60.3	29.8	5.6	2744	-	-	0	-
8	3	0	O	10	0.03	213.8	5.4	44.1	-	1104	1104	142	1246
8	3	20	O	9	0.02	276.9	5.5	47.5	-	935	1031	92	1123
8	3	20	M	16	0.84	26.4	22.0	2.3	1893	-	-	0	-
9	1	0	O	9	0.11	131.1	14.3	24.9	-	2714	2596	183	2778
9	1	0	M	11	0.55	29.0	15.8	2.8	1531	-	-	0	-
9	1	20	M	13	0.11	107.8	12.3	15.9	1815	-	1815	300	2115
9	1	20	M	12	0.65	26.5	17.3	2.1	1380	-	-	0	-
9	2	0	O	7	0.07	203.3	14.0	40.6	-	2786	2189	35	2224
9	2	0	M	12	1.19	20.8	24.7	0.7	796	-	-	0	-
9	2	20	O	16	0.07	112.9	7.7	21.9	-	1498	1498	275	1773

Site	Plot	Meter	Organic/Mineral	Core depth (cm)	BD (g cm <sup>3</sup> )	GWC (%)	VWC (%)	SOM(%)	Mineral soil C (g C m <sup>2</sup> )	Organic soil C (g C m <sup>2</sup> )	Total soil C; 10 cm (g C m <sup>2</sup> )	Root C; 10 cm (g C m <sup>2</sup> )	Total belowground C; 10 cm (g C m <sup>2</sup> )
9	2	20	M	11	0.60	30.3	18.3	1.8	1094	-	-	0	-
9	3	0	O	15	0.08	237.8	19.9	36.2	-	3032	3032	215	3247
9	3	0	M	1	0.75	72.6	54.2	7.3	-	-	-	0	-
9	3	20	M	12	0.26	63.7	16.9	12.5	3319	-	3319	58	3377
9	3	20	M	13	1.00	21.2	21.2	0.9	851	-	-	0	-
10	1	0	O	13	0.05	264.4	13.3	46.4	-	2339	2339	198	2536
10	1	0	M	15	0.91	23.2	21.2	0.9	842	-	-	0	-
10	1	20	O	13	0.08	264.2	21.0	46.4	-	3691	3691	497	4188
10	1	20	M	11	0.85	28.6	24.4	1.8	1565	-	-	0	-
10	2	0	O	15	0.04	261.0	9.3	47.5	-	1691	1691	489	2180
10	2	20	O	14	0.04	346.3	13.9	44.7	-	1795	1795	26	1821
10	2	20	M	12	0.97	22.6	21.9	1.3	1251	-	-	0	-
10	3	0	O	18	0.03	258.8	8.6	35.1	-	1168	1168	45	1213
10	3	0	M	15	0.97	26.0	25.2	1.8	1766	-	-	0	-
10	3	20	O	8	0.05	240.7	11.9	41.3	-	2041	1909	417	2325
10	3	20	M	13	0.72	32.0	23.1	1.9	1379	-	-	0	-
11	1	0	O	10	0.03	161.3	5.6	25.2	-	880	880	531	1412
11	1	0	M	20	1.04	23.7	24.6	1.2	1207	-	-	0	-
11	1	20	O	10	0.15	122.0	18.4	24.2	-	3645	3645	153	3798
11	1	20	M	5	1.15	41.6	47.7	3.1	3505	-	-	0	-
11	2	0	O	12	0.04	112.5	4.5	34.0	-	1357	1357	443	1800
11	2	0	M	15	0.84	34.9	29.4	2.1	1790	-	-	0	-
11	2	20	O	12	0.05	113.6	6.0	27.3	-	1446	1446	123	1568
11	2	20	M	18	0.96	33.1	31.7	2.2	2095	-	-	0	-
11	3	0	O	10	0.02	204.6	3.9	41.9	-	808	808	1350	2158
11	3	0	M	15	0.71	38.8	27.6	3.4	2387	-	-	0	-
11	3	20	M	7	0.18	78.2	13.8	12.8	2257	-	1841	39	1880
11	3	20	M	20	1.02	25.4	25.8	0.9	870	-	-	0	-
12	1	0	O	3	0.15	257.9	39.3	48.0	-	-	-	571	571
12	1	20	O	9	0.03	280.6	8.3	44.7	-	1323	1632	317	1949
12	1	20	M	7	0.97	49.9	48.2	4.6	4409	-	-	0	-

Site	Plot	Meter	Organic/Mineral	Core depth (cm)	BD (g cm <sup>3</sup> )	GWC (%)	VWC (%)	SOM(%)	Mineral soil C (g C m <sup>2</sup> )	Organic soil C (g C m <sup>2</sup> )	Total soil C; 10 cm (g C m <sup>2</sup> )	Root C; 10 cm (g C m <sup>2</sup> )	Total belowground C; 10 cm (g C m <sup>2</sup> )
12	2	0	O	12	0.04	203.3	7.3	39.1	-	1412	1412	131	1543
12	2	20	O	7	0.03	228.0	7.8	43.5	-	1498	1531	263	1794
12	2	20	M	20	0.64	35.1	22.4	2.5	1608	-	-	0	-
12	3	0	O	9	0.03	310.2	10.0	47.8	-	1545	1787	73	1859
12	3	0	M	7	0.52	85.7	44.7	7.6	3956	-	-	0	-
12	3	20	O	13	0.03	206.0	6.4	37.8	-	1175	1175	272	1447
12	3	20	M	6	0.57	62.3	35.7	5.4	3075	-	-	0	-
13	1	0	O	13	0.06	245.9	14.1	37.7	-	2153	2153	309	2462
13	1	0	M	11	0.85	35.1	29.9	2.6	2209	-	-	0	-
13	1	20	O	12	0.04	222.4	9.8	40.3	-	1777	1777	324	2101
13	2	0	O	7	0.03	200.3	5.7	37.8	-	1073	1166	27	1193
13	2	0	M	14	0.38	45.1	17.2	3.6	1383	-	-	0	-
13	2	20	O	19	0.07	192.5	14.2	36.7	-	2711	2711	514	3225
13	3	0	O	12	0.02	153.8	2.8	41.2	-	738	738	301	1039
13	3	0	M	4	0.77	85.2	65.6	6.9	-	-	-	0	-
13	3	20	O	11	0.03	149.4	4.6	46.4	-	1420	1420	125	1545
13	3	20	M	14	0.82	29.2	24.0	2.8	2297	-	-	0	-
14	1	0	M	2	0.59	74.0	44.0	12.9	2361	-	2361	40	2401
14	1	0	M	12	0.53	28.2	14.9	2.0	1041	-	-	0	-
14	1	20	O	6	0.14	193.2	26.9	29.6	-	4125	3028	221	3250
14	1	20	M	12	0.98	26.4	25.9	1.4	1384	-	-	0	-
14	2	0	O	12	0.05	184.2	8.7	46.5	-	2200	2200	640	2840
14	2	0	M	16	0.58	22.0	12.8	1.2	683	-	-	0	-
14	2	20	O	11	0.12	163.8	19.6	23.6	-	2823	2823	130	2954
14	2	20	M	16	0.78	24.2	18.8	1.1	828	-	-	0	-
14	3	0	O	11	0.12	110.4	13.6	30.6	-	3759	3759	268	4028
14	3	0	M	13	1.24	21.8	27.0	1.3	1593	-	-	0	-
14	3	20	O	7	0.09	177.1	15.1	31.5	-	2692	2276	0	2276
14	3	20	M	12	1.04	20.6	21.5	1.3	1306	-	-	0	-
15	1	0	O	10	0.08	209.2	17.8	32.4	-	2750	2750	87	2837
15	1	0	M	13	1.18	24.3	28.7	1.2	1409	-	-	0	-

Site	Plot	Meter	Organic/Mineral	Core depth (cm)	BD (g cm <sup>3</sup> )	GWC (%)	VWC (%)	SOM(%)	Mineral soil C (g C m <sup>2</sup> )	Organic soil C (g C m <sup>2</sup> )	Total soil C; 10 cm (g C m <sup>2</sup> )	Root C; 10 cm (g C m <sup>2</sup> )	Total belowground C; 10 cm (g C m <sup>2</sup> )
15	1	20	O	12	0.03	573.5	18.2	43.5	-	1382	1382	86	1467
15	1	20	M	14	0.71	68.0	48.1	5.0	3524	-	-	0	-
15	2	0	O	9	0.03	364.4	11.9	41.5	-	1358	1489	217	1706
15	2	0	M	12	0.86	44.3	38.1	3.1	2670	-	-	0	-
15	2	20	O	19	0.01	983.2	14.7	46.9	-	700	700	13	713
15	3	0	O	6	0.11	287.0	33.0	38.4	-	4412	3045	79	3124
15	3	0	M	20	0.91	23.0	21.0	1.1	994	-	-	0	-
15	3	20	O	16	0.04	322.3	11.9	45.1	-	1664	1664	237	1901
15	3	20	O	2	0.74	193.8	142.6	20.6	-	-	-	0	-
16	1	0	O	9	0.04	339.7	12.1	47.4	-	1694	1827	151	1978
16	1	0	M	10	0.92	45.2	41.6	3.3	3032	-	-	0	-
16	1	20	O	17	0.05	287.1	13.1	39.3	-	1793	1793	64	1857
16	2	0	M	10	0.07	109.8	8.1	19.3	1425	-	1425	98	1523
16	2	0	M	17	1.03	22.6	23.3	1.3	1292	-	-	0	-
16	2	20	O	9	0.07	114.3	8.4	40.3	-	2972	2853	630	3483
16	2	20	M	14	1.06	24.9	26.5	1.7	1785	-	-	0	-
16	3	0	O	16	0.03	241.3	6.8	39.6	-	1120	1120	79	1199
16	3	0	M	19	0.73	44.9	32.6	4.0	2875	-	-	0	-
16	3	20	O	18	0.03	298.8	8.1	34.4	-	936	936	24	960
17	1	0	M	10	0.34	41.3	14.1	5.0	1714	-	1714	0	1714
17	1	20	M	12	0.15	73.2	10.7	15.4	2242	-	2242	172	2414
17	1	20	M	10	0.81	31.9	26.0	3.0	2418	-	-	0	-
17	3	0	M	10	0.18	78.6	14.1	19.8	3541	-	3541	111	3652
17	3	0	M	10	0.75	32.8	24.6	2.7	1987	-	-	0	-
17	3	20	M	9.5	0.27	63.0	17.0	13.6	3676	-	3543	399	3942
17	3	20	M	10	0.73	35.3	25.7	1.4	1013	-	-	0	-
18	1	0	M	19	0.03	207.6	6.9	15.1	505	-	505	14	519
18	1	0	M	25	0.08	115.8	9.6	4.8	397	-	-	0	-
18	1	20	O	17	0.03	510.1	15.1	46.0	-	1363	1363	136	1499
18	2	0	O	12	0.07	294.7	19.3	40.1	-	2625	2625	142	2766
18	2	0	M	5	0.56	112.3	63.2	10.8	6055	-	-	0	-



Site	Plot	Meter	Organic/Mineral	Core depth (cm)	BD (g cm <sup>3</sup> )	GWC (%)	VWC (%)	SOM(%)	Mineral soil C (g C m <sup>2</sup> )	Organic soil C (g C m <sup>2</sup> )	Total soil C; 10 cm (g C m <sup>2</sup> )	Root C; 10 cm (g C m <sup>2</sup> )	Total belowground C; 10 cm (g C m <sup>2</sup> )
18	2	20	O	18	0.03	371.4	11.6	46.8	-	1462	1462	139	1601
18	2	20	M	10	0.86	57.1	49.4	4.2	3673	-	-	0	-
18	3	0	O	19	0.08	310.6	23.8	38.2	-	2930	2930	22	2952
18	3	20	O	23	0.09	247.1	22.3	28.3	-	2552	2552	36	2588
19	1	0	M	14	0.08	130.9	10.9	18.1	1512	-	1512	610	2122
19	1	0	M	1	1.13	35.6	40.3	2.2	-	-	-	0	-
19	2	0	O	10	0.12	329.6	38.4	34.3	-	3987	3987	296	4283
19	2	0	M	6	0.75	61.8	46.1	5.3	3974	-	-	0	-
19	3	0	O	13.5	0.12	176.3	21.0	25.5	-	3041	3041	114	3156
20	1	1	M	12	1.31	23.3	30.5	1.2	1505	-	1505	0	-
20	1	NA	O	10	0.10	52.4	5.2	30.0	-	2961	2961	-	-
20	2	2	M	10	1.22	21.5	26.1	0.7	800	-	800	0	-
20	2	NA	O	7	0.03	243.3	6.1	42.1	-	1056	1056	-	-
20	3	1	M	22	1.61	22.9	36.7	1.1	1748	-	1748	0	-
20	3	2	M	11	1.45	23.3	33.9	1.1	1573	-	1573	0	-
20	3	NA	O	9	0.12	233.4	29.0	26.7	-	3313	3313	-	-
20	4	NA	O	NA	0.06	290.5	18.3	35.3	-	-	-	-	-

\* Soils from site 20 were not collected at either end of the 20-m-long plots, but were spaced ~10m apart; mineral and organic soils were collected from adjacent areas but from different cores.

**Table S4.** Soil characteristics of surface permafrost cores (frozen active layer and surface permafrost; type=F) and thawed active layer mineral soils (type=TM) in the Y4 watershed. Depths reflect distance from the top of the mineral layer. Soil carbon pools are reported for each depth increment. Active layer organic soil data are in Table S3.

Site	Core	Type	Depth (cm)	Organic Matter Content (%)	Carbon Content (%)	Gravimetric Water Content (%)	Bulk Density (g cm <sup>-3</sup> )	Soil C (kg m <sup>-2</sup> )
1	1	TM	0-28	3.66	1.34	24	1.04	3.92
1	1	TM	28-51	2.77	0.88	24	0.84	1.69
1	1	F	51-60	2.58	0.78	78	0.93	0.72
1	1	F	60-70	2.60	0.79	96	0.88	0.70
1	1	F	70-82	3.04	1.02	198	0.42	0.51
1	1	F	82-92	2.87	0.93	116	0.60	0.56
1	1	F	92-102.5	2.67	0.82	109	0.55	0.48
1	1	F	102.5-108.5	2.61	0.79	117	0.63	0.79
1	2	TM	0-26	3.80	1.42	25	0.83	3.05
1	2	TM	26-39	3.15	1.07	24	1.12	1.57
1	2	F	39-50	2.51	0.74	69	0.84	0.68
1	2	F	50-60	2.50	0.74	127	0.67	0.50
1	2	F	60-71	2.24	0.60	72	0.93	0.61
1	2	F	71-81	2.39	0.68	89	0.78	0.53
1	2	F	81-91	2.31	0.63	76	0.81	0.52
1	2	F	91-102	2.67	0.83	68	0.91	0.83
1	2	F	102-112	2.69	0.84	77	0.85	0.71
1	2	F	112-121	3.04	1.02	70	0.83	0.76
1	3	TM	0-27	4.15	1.60	29	0.70	3.02
1	3	TM	27-45	2.75	0.86	22	1.08	1.67
1	3	F	45-50	-	1.32	32	1.13	0.66
1	3	F	50-60	2.11	0.53	72	1.00	0.47
1	3	F	60-71	2.66	0.82	114	0.76	0.52
1	3	F	71-81	2.63	0.80	79	0.87	0.67
1	3	F	81-90	2.73	0.85	116	0.73	0.42
1	3	F	90-101	2.73	0.85	114	0.70	0.57
1	3	F	101-112	2.70	0.84	96	0.61	0.59
2	1	TM	0-38	4.03	1.54	30	0.64	3.74
2	1	F	38-51	5.20	2.15	50	1.20	3.35
2	1	F	51-60	3.69	1.36	134	0.53	0.65
2	1	F	60-69	-	1.26	129	0.50	0.57
2	1	F	69-81	3.32	1.17	130	0.59	0.83
2	1	F	81-90	2.53	0.75	108	0.73	0.49
2	1	F	90-99	2.52	0.75	127	0.59	0.40
2	1	F	99-109.5	2.24	0.60	148	0.56	0.35
2	2	TM	0-26	2.98	0.98	22	1.00	2.57
2	2	TM	26-42	3.11	1.05	28	0.87	1.47
2	2	F	42-50	2.89	0.94	66	0.97	0.73
2	2	F	50-60	2.76	0.87	75	0.78	0.68
2	2	F	60-74	3.26	1.13	105	0.69	1.03
2	2	F	74-84	2.66	0.82	89	0.85	0.69
2	2	F	84-95	2.64	0.81	105	0.70	0.62
2	2	F	95-104	3.78	1.41	81	0.81	1.03
2	2	F	104-111	4.02	1.53	71	0.87	0.94

Site	Core	Type	Depth (cm)	Organic Matter Content (%)	Carbon Content (%)	Gravimetric Water Content (%)	Bulk Density (g cm <sup>-3</sup> )	Soil C (kg m <sup>-2</sup> )
2	3	TM	0-29	4.60	1.83	35	0.81	4.30
2	3	F	29-40	3.34	1.18	80	1.15	1.49
2	3	F	40-49	2.82	0.90	169	0.46	0.37
2	3	F	49-60	3.31	1.16	65	1.07	1.36
2	3	F	60-68	2.99	0.99	103	0.72	0.57
2	3	F	68-80	3.15	1.07	101	0.90	1.16
2	3	F	80-90	3.31	1.16	114	0.60	0.69
2	3	F	90-95	3.05	1.02	120	0.75	0.38
7	1	TM	0-23	4.09	1.57	31	0.92	3.32
7	1	F	23-31	3.54	1.28	143	0.54	0.49
7	1	F	31-38	3.35	1.18	372	0.31	0.17
7	1	F	38-51	3.34	1.18	134	0.60	0.77
7	1	F	51-62	3.07	1.03	45	1.19	1.07
7	1	F	62-72	2.73	0.85	69	1.01	0.76
7	1	F	72-81	4.20	1.63	85	0.87	1.06
7	2	TM	0-2.5	14.04	6.78	77	0.49	0.82
7	2	F	2.5-12	5.13	2.11	44	1.04	2.05
7	2	F	12-23	4.03	1.54	109	0.76	1.00
7	2	F	23-33	3.46	1.24	147	0.65	0.61
7	2	F	33-44	3.49	1.25	126	0.70	0.87
7	2	F	44-55	3.96	1.50	62	0.81	1.35
7	2	F	55-67	4.44	1.75	70	0.99	1.84
7	2	F	67-79	5.34	2.22	190	0.38	0.87
7	2	F	79-90	4.25	1.65	225	0.34	0.54
7	2	F	90-103	3.01	1.00	142	0.60	0.68
7	3	TM	0-25.5	5.14	2.12	31	0.80	4.32
7	3	TM	25.5-29	3.68	1.36	24	2.71	1.28
7	3	F	29-40	3.96	1.50	63	1.06	1.66
7	3	F	40-51	3.20	1.10	87	0.77	0.78
7	3	F	51-62	3.54	1.28	267	0.31	0.39
7	3	F	62-71	2.40	0.68	102	0.83	0.37
7	3	F	71-83	2.63	0.80	115	0.80	0.63
9	1	TM	0-19	3.65	1.33	25	0.74	1.88
9	1	F	19-30	2.48	0.73	130	0.74	0.59
9	1	F	30-41	2.51	0.74	53	0.82	0.67
9	1	F	41-53	2.66	0.82	38	1.61	1.58
9	1	F	53-63	2.38	0.67	81	0.74	0.50
9	1	F	63-69	1.53	0.23	70	0.95	0.13
9	2	TM	0-30	2.92	0.95	20	1.14	3.25
9	2	TM	30-41.5	2.76	0.87	21	0.44	1.59
9	2	F	41.5-49	1.97	0.46	65	0.94	0.32
9	2	F	49-58	2.12	0.53	83	0.92	0.44
9	2	F	58-67	2.14	0.54	120	0.58	0.29
9	2	F	67-77	2.08	0.52	80	0.83	0.43
9	2	F	77-86	2.00	0.47	100	0.69	0.29
9	2	F	86-95	2.16	0.56	125	0.57	0.29
9	2	F	95-102	2.20	0.58	77	0.76	0.31
9	3	TM	0-33.5	2.76	0.87	23	0.77	2.25

Site	Core	Type	Depth (cm)	Organic Matter Content (%)	Carbon Content (%)	Gravimetric Water Content (%)	Bulk Density (g cm <sup>-3</sup> )	Soil C (kg m <sup>-2</sup> )
9	3	F	34-40	2.41	0.69	43	0.87	0.36
9	3	F	40-48	2.09	0.52	92	0.89	0.37
9	3	F	48-58	2.00	0.47	197	0.78	0.37
9	3	F	58-68	2.10	0.52	64	0.90	0.47
9	3	F	68-82	2.05	0.50	98	0.74	0.52
10	1	TM	0-3.5	4.77	1.92	43	0.76	0.51
10	1	F	3.5-11	2.07	0.51	42	1.18	0.44
10	1	F	11-20	2.67	0.82	125	0.74	0.34
10	1	F	20-32	-	0.85	104	0.59	0.55
10	1	F	32-40	2.77	0.88	103	0.66	0.40
10	1	F	40-51	2.64	0.81	96	0.64	0.67
10	1	F	51-65	3.86	1.45	223	0.39	0.79
10	2	TM	0-23.5	4.59	1.83	35	0.74	3.20
10	2	F	23.5-30	4.54	1.80	50	1.18	1.38
10	2	F	30-41	2.63	0.80	91	0.76	0.67
10	2	F	41-51	2.31	0.64	173	0.49	0.31
10	2	F	51-62	2.51	0.74	90	0.66	0.54
10	2	F	62-72	2.40	0.68	212	0.29	0.20
10	2	F	72-81	2.20	0.58	133	0.19	0.10
10	2	F	81-91	2.52	0.74	82	0.84	0.62
10	3	TM	0-2.5	7.38	3.29	47	0.66	0.54
10	3	F	2.5-9	2.05	0.50	57	1.01	0.32
10	3	F	9-19	3.80	1.42	71	0.78	1.22
10	3	F	19-29	3.71	1.37	111	0.58	0.78
10	3	F	29-41	4.54	1.80	233	0.31	0.73
10	3	F	41-51	4.93	2.01	155	0.45	0.87
10	3	F	51-59	2.90	0.95	99	0.74	0.45
16	1	TM	0-33.5	2.98	0.98	23	0.54	1.79
16	1	F	33.5-40	3.54	1.28	48	1.00	0.86
16	1	F	40-50	3.16	1.08	85	0.82	0.71
16	1	F	50-61	2.81	0.90	48	1.08	1.02
16	1	F	61-72	3.59	1.31	84	0.53	0.87
16	1	F	72-81	3.12	1.06	451	0.21	0.17
16	1	F	81-88	3.28	1.15	655	0.16	0.10
16	2	TM	0-23	5.35	2.23	33	0.61	3.13
16	2	F	23-30	3.10	1.05	46	1.35	0.99
16	2	F	30-41	3.01	1.00	253	0.29	0.32
16	2	F	41-52	4.07	1.56	598	0.17	0.29
16	2	F	52-65	2.66	0.82	391	0.21	0.22
16	2	F	65-70	3.34	1.18		0.07	0.04
16	2	F	70-80	2.86	0.92	328	0.18	0.16
16	3	TM	0-29	14.86	4.76	22	0.86	12.54
16	3	TM	29-37.5	2.79	0.89	23	2.36	1.78
16	3	F	37.5-49	3.43	1.22	136	0.53	0.75
16	3	F	49-52	3.23	1.12	265	0.31	0.10
16	3	F	52-63	5.78	2.46	168	0.54	1.09
16	3	F	63-75	5.82	2.48	137	0.55	1.64

Site	Core	Type	Depth (cm)	Organic Matter Content (%)	Carbon Content (%)	Gravimetric Water Content (%)	Bulk Density (g cm <sup>-3</sup> )	Soil C (kg m <sup>-2</sup> )
16	3	F	75-87	3.76	1.39	178	0.46	0.69
20	1	TM	0-12	3.30	1.15	23	1.31	1.81
20	1	F	12-28	2.52	0.74	27	0.97	1.16
20	1	F	28-36	2.27	0.61	22	1.92	0.95
20	1	F	36-46	2.26	0.61	43	1.40	0.86
20	1	F	46-57	2.14	0.55	72	0.88	0.53
20	1	F	57-68	2.03	0.49	149	0.54	0.29
20	2	TM	0-14	3.08	1.04	20	2.48	3.60
20	2	TM	14-24	2.35	0.66	21	1.22	0.80
20	2	F	44-50	2.81	0.90	28	1.88	1.01
20	2	F	50-60	2.19	0.57	62	1.04	0.60
20	2	F	60-70	1.93	0.43	87	0.81	0.35
20	2	F	70-78	2.06	0.51	92	0.89	0.36
20	3	TM	0-22	3.17	1.09	23	1.61	3.84
20	3	TM	22-33	3.17	1.08	23	1.45	1.73
20	3	F	33-40	2.06	0.51	30	1.14	0.40
20	3	F	40-48	2.17	0.56	57	1.04	0.47
20	3	F	48-55	2.00	0.47	25	1.63	0.54
20	3	F	55-65	2.42	0.69	124	0.71	0.49

**Table S5.** Gravimetric water content (GWC), soil organic matter content (SOM), and bulk density (BD) from 15-m-deep permafrost cores collected from alas (site 18) and yedoma (site 19) sites. Sampling depth intervals varied for BD, and for GWC and SOM. Depths represent distance from the ground surface and include active layer soils.

Site	Interval (m)	GWC, %	SOM (%)	BD Interval (m)	BD (g cm <sup>-3</sup> )
18	0.12-0.14	220.72	25.19	0.14-0.16	0.24
18	0.22-0.23	200.68	17.05	0.23-0.24	0.39
18	0.43-0.44	241.27	9.83	0.44-0.47	0.31
18	0.60-0.61	231.72	13.83	0.61-0.63	0.38
18	0.70-0.86	427.03	47.36	0.94-0.96	0.47
18	0.93-0.94	166.05	35.76	1.20-1.22	0.09
18	1.18-1.20	913.89	69.83	1.42-1.44	0.13
18	1.40-1.42	642.22	77.80	1.52-1.53	0.79
18	1.51-1.52	74.73	6.48	1.75-1.79	0.22
18	1.73-1.75	464.86	6.67	1.97-2.06	1.02
18	1.99-2.01	35.95	3.83	2.20-2.25	0.85
18	2.40-2.42	43.09	3.44	3.10-3.18	1.13
18	2.50-2.52	49.04	2.70	3.62-3.66	1.28
18	2.68-2.70	42.57	4.02	3.96-4.00	1.11
18	2.95-2.98	43.26	4.90	4.15-4.17	1.05
18	3.25-3.27	36.21	5.18	4.33-4.36	1.00
18	3.35-3.38	38.46	5.75	4.63-4.66	1.12
18	3.59-3.62	40.48	6.03	5.06-5.10	1.17
18	3.92-3.96	43.57	6.51	5.26-5.30	1.13
18	4.12-4.15	52.22	5.95	5.43-5.46	1.30
18	4.30-4.33	42.28	5.45	5.58-5.661	1.29
18	4.60-4.63	45.91	6.83	6.07-6.09	1.28
18	5.03-5.06	42.56	6.43	6.28-6.30	1.04
18	5.23-5.26	45.69	6.30	6.48-6.52	1.28
18	5.40-5.43	45.12	5.90	6.65-6.68	1.21
18	5.55-5.58	37.10	4.63	7.02-7.06	1.56
18	5.99-6.07	40.26	6.49	7.36-7.40	1.34
18	6.24-6.26	50.77	3.86	7.65-7.70	1.33
18	6.45-6.48	31.40	3.88	7.95-8.00	1.52
18	6.61-6.65	37.56	5.42	8.39-8.44	1.50
18	7.02-7.06	22.26	3.21	8.69-8.75	1.38
18	7.36-7.40	39.90	4.77	9.16-9.21	1.34
18	7.65-7.70	35.80	4.00	9.50-9.56	1.22
18	7.90-7.95	31.40	3.88	10.17-10.22	1.51
18	8.36-8.39	33.20	3.20	10.45-10.50	0.97
18	8.63-8.68	30.94	3.21	10.87-10.91	1.27
18	9.13-9.16	34.66	3.95	11.15-11.20	1.20
18	9.50-9.56	35.42	3.32	11.27-11.31	1.14
18	10.13-10.17	32.48	3.97	11.51-11.59	1.28
18	10.45-10.50	44.83	4.72	11.88-11.91	1.17
18	10.83-10.87	43.17	5.23	12.16-12.21	1.19
18	11.12-11.15	45.07	15.61	12.38-12.43	1.39
18	11.25-11.27	33.57	4.83	12.67-12.72	1.30

Site	Interval (m)	GWC, %	SOM (%)	BD Interval (m)	BD (g cm <sup>-3</sup> )
18	11.46-11.51	35.84	4.74	13.10-13.17	1.30
18	11.86-11.88	36.14	4.75	14.09-14.14	1.40
18	12.13-12.16	32.74	4.32	14.85-14.89	1.40
18	12.35-12.38	31.77	3.45	15.18-15.25	1.34
18	12.67-12.72	32.01	4.00		
18	13.03-13.10	33.92	4.03		
18	14.05-14.09	26.65	3.09		
18	14.48-14.55	29.71	3.33		
18	15.12-15.18	30.56	4.27		
19	0.02 - 0.07	105.10	-	0.02 - 0.07	0.25
19	0.05 - 0.1	48.65	2.14	-	-
19	0.09 - 0.14	17.32	2.74	0.09 - 0.14	1.77
19	0.15 - 0.2	26.79	-	-	-
19	0.16 - 0.21	18.07	9.63	0.16 - 0.21	1.67
19	0.25 - 0.30	155.51	-	0.25 - 0.3	0.79
19	0.30 - 0.35	17.93	5.22	-	-
19	0.33 - 0.38	19.95	2.55	0.33 - 0.38	1.68
19	0.4 - 0.45	20.65	2.14	0.4 - 0.45	1.57
19	0.43 - 0.50	17.91	3.60	1.3 - 1.35	0.95
19	0.55 - 0.60	11.20	2.84	1.6 - 1.65	1.20
19	0.55 - 0.57	17.39	1.98	1.7 - 1.75	1.01
19	0.65 - 0.70	10.98	2.75	1.85 - 1.9	1.20
19	0.75 - 0.80	9.18	4.57	2 - 2.05	1.13
19	0.90 - 1.00	45.73	2.53	2.25 - 2.32	1.25
19	1.00 - 1.15	89.96	1.25	2.53 - 2.58	1.07
19	1.30 - 1.35	63.99	2.50	2.7 - 2.76	1.10
19	1.60 - 1.65	41.54	2.39	2.75 - 2.79	0.95
19	1.70 - 1.75	44.99	3.49	2.8 - 2.86	1.23
19	1.85 - 1.90	45.80	2.97	3.08 - 3.11	0.97
19	2.12 - 2.20	42.65	2.82	3.2 - 3.24	1.01
19	2.58 - 2.60	46.20	4.99	3.4 - 3.43	1.09
19	2.76 - 2.80	39.11	3.75	3.45 - 3.48	1.12
19	2.97 - 3.00	45.41	3.55	3.59 - 3.62	0.82
19	3.00 - 3.08	48.84	3.11	3.75 - 3.77	0.93
19	3.11 - 3.15	45.45	3.77	3.8 - 3.83	1.12
19	3.24 - 3.27	48.75	2.84	3.91 - 3.93	1.11
19	3.43 - 3.45	53.25	4.53	4.02 - 4.06	1.23
19	3.48 - 3.51	48.75	4.25	4.15 - 4.2	1.09
19	3.62 - 3.65	60.52	4.33	4.45 - 4.48	1.03
19	3.77 - 3.8	61.94	4.48	4.62 - 4.65	1.04
19	3.83 - 3.86	45.63	4.17	4.79 - 4.82	1.04
19	3.93 - 3.95	35.92	6.21	4.92 - 4.95	0.87
19	4.06 - 4.09	42.83	4.90	5.15 - 5.18	1.09
19	4.09 - 4.15	46.88	3.81	5.35 - 5.37	1.06
19	4.2 - 4.23	55.08	4.66	5.4 - 5.43	0.97

Site	Interval (m)	GWC, %	SOM (%)	BD Interval (m)	BD (g cm <sup>-3</sup> )
19	4.48 - 4.52	53.69	3.80	5.89 - 5.91	0.93
19	4.65 - 4.69	47.08	5.14	5.66 - 5.69	1.07
19	4.82 - 4.85	50.47	4.96	6.13 - 6.16	1.08
19	4.95 - 4.98	43.33	3.48	6.23 - 6.26	1.11
19	5.18 - 5.21	42.45	4.44	6.4 - 6.43	1.07
19	5.21 - 5.28	46.83	3.95	6.55 - 6.58	1.08
19	5.37 - 5.4	53.57	3.93	6.7 - 6.75	1.09
19	5.43 - 5.47	51.93	4.29	7.04 - 7.07	1.06
19	5.69 - 5.73	47.90	2.20	7.26 - 7.3	1.08
19	5.91 - 5.95	63.80	4.65	7.4 - 7.44	1.04
19	6.1 - 6.13	48.53	5.34	7.6 - 7.65	1.06
19	6.16 - 6.26	46.71	3.40	7.78 - 7.82	0.96
19	6.26 - 6.3	45.04	3.79	7.9 - 7.94	0.95
19	6.43 - 6.47	45.96	4.15	8.08 - 8.12	1.11
19	6.58 - 6.62	49.56	5.22	8.24 - 8.27	0.93
19	6.75 - 6.8	44.53	3.16	8.4 - 8.42	1.08
19	7.00 - 7.04	47.58	4.69	8.53 - 8.56	0.99
19	7.07 - 7.14	49.05	4.16	8.73 - 8.77	0.91
19	7.23 - 7.26	45.77	4.92	8.9 - 8.94	0.95
19	7.57 - 7.6	50.79	4.89	9.05 - 9.09	0.67
19	7.75 - 7.78	56.61	7.14	9.22 - 9.25	0.65
19	7.94 - 7.98	54.77	7.90	9.53 - 9.57	0.99
19	8.12 - 8.15	39.58	3.35	9.75 - 9.8	1.20
19	8.27 - 8.30	56.99	7.41	9.8 - 9.84	1.21
19	8.56 - 8.59	41.76	2.28	10.05 - 10.08	1.27
19	8.77 - 8.80	55.15	2.49	10.21 - 10.24	1.25
19	8.85 - 8.90	66.56	0.78	10.47 - 10.5	1.23
19	8.94 - 8.97	48.56	2.52	10.64 - 10.67	1.32
19	9.09 - 9.12	99.67	2.44	10.83 - 10.85	1.18
19	9.25 - 9.27	108.05	2.40	10.95 - 11.01	1.26
19	9.57 - 9.60	59.46	2.65	11.15 - 11.19	1.19
19	9.70 - 9.72	45.91	2.82	11.33 - 11.36	1.03
19	9.75 - 9.8	47.23	1.68	11.63 - 11.67	1.16
19	9.84 - 9.87	36.05	3.02	11.83 - 11.87	1.21
19	10.08 - 10.12	37.06	3.27	12.16 - 12.2	1.36
19	10.12 - 10.21	37.94	1.78	12.25 - 12.3	1.26
19	10.24 - 10.28	36.44	2.84	12.16 - 12.2	1.34
19	10.45 - 10.47	35.49	1.81	12.25 - 12.3	1.21
19	10.64 - 10.67	33.68	3.44	12.44 - 12.47	0.96
19	10.81 - 10.83	41.61	2.76	13.15 - 13.2	1.21
19	11.01 - 11.05	38.47	2.04	13.43 - 13.48	1.28
19	11.19 - 11.23	40.69	2.95	13.73 - 13.78	1.10
19	11.36 - 11.39	40.67	2.86	13.83 - 13.87	1.18
19	11.45 - 11.63	38.85	2.37	14.1 - 14.14	1.26



---

Site	Interval (m)	GWC, %	SOM (%)	BD Interval (m)	BD (g cm <sup>-3</sup> )
19	11.67 - 11.96	37.12	2.89	14.27 - 14.31	1.31
19	11.78 - 11.83	37.30	2.52	14.41 - 14.46	1.30
19	11.87 - 11.90	36.23	1.85	14.65 - 14.7	1.20
19	12.13 - 12.16	36.71	2.32	15.04 - 15.08	1.21
19	12.20 - 12.25	38.10	1.54		
19	12.30 - 12.33	42.06	2.75		
19	12.79 - 12.82	93.52	3.67		
19	13.00 - 13.02	44.99	2.84		
19	13.10 - 13.15	36.79	3.12		
19	13.4 - 13.43	33.95	3.04		
19	13.48 - 13.6	35.55	2.17		
19	13.7 - 13.73	40.19	2.64		
19	14.05 - 14.1	38.15	3.52		
19	14.23 - 14.27	36.09	3.26		
19	14.31 - 14.41	35.82	2.58		
19	14.46 - 14.5	36.61	3.29		
19	14.6 - 14.65	36.90	3.30		
19	14.81 - 14.85	38.85	3.46		
19	14.95 - 15.04	38.46	2.07		
19	15.08 - 15.10	39.42	1.95		

---

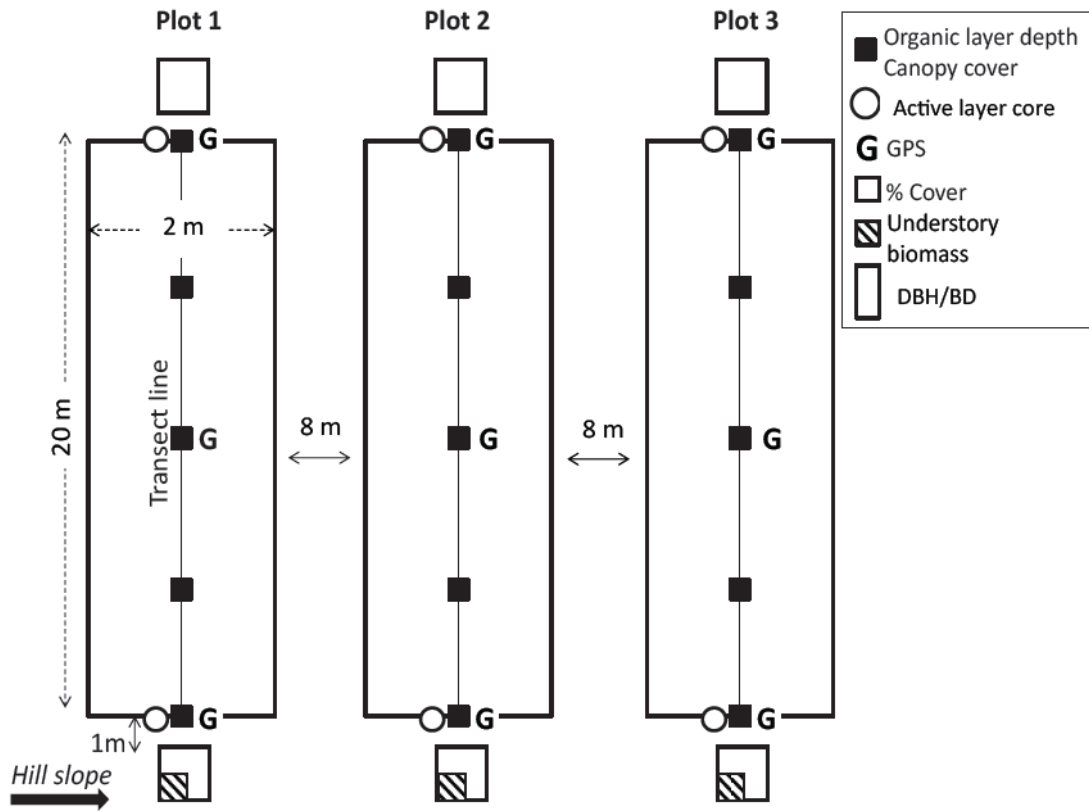

Figure S1. Sampling design for vegetation and soil sampling from 20 sites in the Y4 watershed. At the seven sites where surface permafrost was sampled, permafrost cores (to 1 m) were collected at three of the six active layer soil sampling locations. DBH: diameter at breast height; BD: basal diameter.