

## ANSWER TO REVIEW ONE

*This paper analyzed the carbon use efficiency (CUE, the ratio of NPP to GPP) of a Mediterranean forest and its response to drought. It found the CUE is conservative compared with GPP and NPP but still decreases with drought. The data reported in this study is informative and useful to understanding plant responses to drought and modeling studies. The paper is well written overall, but I still have some concerns on the presentation and explanations of the data.*

- 1. The authors also reported heterotrophic respiration ( $R_h$ ), ecosystem respiration ( $R_{eco}$ ) and ecosystem net production (NEP) besides GPP, NPP, and  $R_a$  that are necessary for estimating CUE. They are not related to the objectives of this study: CUE and its responses to drought. To evaluate  $R_h$ ,  $R_{eco}$ , and NEP, it needs to have the data of litter and soil carbon decomposition rates that are not described in this study.  $R_{eco}$  is the sum of  $R_a$  and  $R_h$ . NEP is the difference between GPP and  $R_{eco}$ , or NPP and  $R_h$ . So, they are not independent variables. It seems not necessary to include the data of  $R_h$ ,  $R_{eco}$ , and NEP in this paper.*

The starting point of this work were the contrasted highly significant linear declines of  $NEP$ ,  $GPP$  and  $R_{eco}$  with drought severity evaluated through the Water Stress Integral (WSI) (see Table 1 lines 1 to 3 and Figure 1) that we observed over a continuous period of 10 years. One central objective of this work is to examine how drought affects CUE. However, we had other objectives:

1. We wish to provide a picture of the carbon fluxes and stock in our ecosystems. We believe this is important as it will facilitate future synthesis and future comparison among ecosystems. Actually, parameters NEE, GPP, and  $R_{eco}$  are widely and routinely estimated among ecosystems (through the different national, European and world networks) and thus the most robustly comparable.
2. We also wanted to evaluate the responses of NEP and  $R_{eco}$  to WSI, as it is not common to have more than a decade of these data together with WSI. We think this information is worthy and should be kept. Moreover, with these data we have tried to close a complete ecosystem carbon balance. We have used the same equations used by other authors to this end, assuming a steady-state of ecosystem

compartments:  $GPP = ANPP + R_{aa} + TBCF$ ;  $TBCF = BNPP + R_{ab} + R_h$ ;  $R_h = R_{eco} - R_{aa} - R_{ab}$ . We acknowledge some limitations to this approach coming from estimations of  $R_{ab}$  and  $R_h$ . However, we note our values are similar to those obtained by other authors (Rodeghiero and Cescatti 2006; Litton and Giardina 2008).

In our paper we used concurrent data based on shorter periods to constrain our estimates. Unfortunately it was difficult to measure continuously the soil  $CO_2$  efflux  $F_{sol}$  such as did Misson et al. (2010) for two successive years, or leaf dark respiration or stem  $CO_2$  efflux by daily sampling as did Rodríguez-Calcerrada et al. (2011 and 2014). All these values help us to propose a coherent estimate of the whole carbon budget. The methods concerning measurement of  $F_{sol}$ , and upscaling to the whole-canopy leaf dark respiration and stem  $CO_2$  efflux were detailed in the referenced corresponding papers:

Misson, L., Rocheteau, A., Rambal, S., Ourcival, J.-M., Limousin, J.-M., and Rodriguez, R.: Functional changes in the control of carbon fluxes after 3 years of increased drought in a Mediterranean evergreen forest?, *Glob. Change Biol.*, 16, 2461–2475, doi:10.1111/j.1365-2486.2009.02121.x, 2010

Rodríguez-Calcerrada, J., Jaeger, C., Limousin, J. M., Ourcival, J. M., Joffre, R., and Rambal, S.: Leaf  $CO_2$  efflux is attenuated by acclimation of respiration to heat and drought in a Mediterranean tree, *Funct. Ecol.*, 25, 983–995, doi:10.1111/j.1365-2435.2011.01862.x, 25 2011.

Rodríguez-Calcerrada, J., Martin-StPaul, N. K., Lempereur, M., Ourcival, J.-M., Rey, M.-D.-C., Joffre, R., and Rambal, S.: Stem  $CO_2$  efflux and its contribution to ecosystem  $CO_2$  efflux decrease with drought in a Mediterranean forest stand, *Agr. Forest Meteorol.*, doi:10.1016/j.agrformet.2014.04.012, 2014

2. *The description of data collection and analysis I can't get a clear picture on how GPP, NPP, and  $R_a$  were measured or estimated. I think the sections of 2.2, 2.5, and can be put together, because they are all about the estimation of carbon fluxes (GPP, NPP,  $R_a$ , et al.). But I still can't get how  $R_a$  is estimated. I also don't know how many samples were taken and how the uncertainty of data was estimated. There are no error bars for the data in Fig. 1 (GPP and NPP).*

We did not plot error bars in GPP and NEP (not NPP) in Figure 1. We have an error estimate did by Stauch et al. (2008) on NEE. In our eddy flux tower, she evaluated this error to be 6.5%. Further Misson et al. (2010) expected errors of 20, 30 and 40 g C m<sup>-2</sup> for NEE, GPP and  $R_{eco}$ , respectively (line 10 page 12). Furthermore as NEE, GPP and  $R_{eco}$  constitute direct measurements of C fluxes at the stand scale, they are less subjected to uncertainties than the other individual fluxes based on upscaling methodologies (e.g. production, respiration).

*I think the sections of 2.2, 2.5, and can be put together, because they are all about the estimation of carbon fluxes (GPP, NPP, Ra, et al.)*

OK we moved 2.2

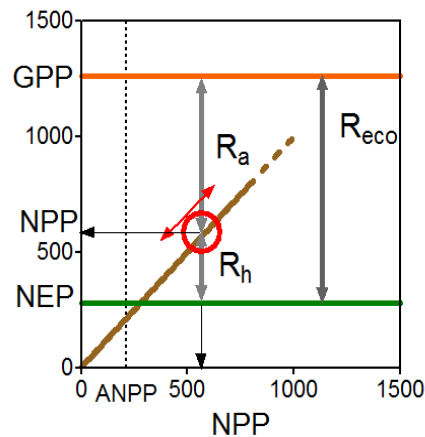

**Figure 1.** Scheme showing how the biometric estimate of NPP determines the partition of  $R_{eco}$  in its components  $R_a$  and  $R_h$ . In this figure, we plot GPP, NEP and NPP at their average values. We could see how error in estimating NPP propagates in  $R_a$  and  $R_h$ .

We acknowledge that we have provided few explanations of the methods we used to estimate  $R_a$  (see Figure 1). Perhaps the reviewer is confused because in the methods (page 12, lines 18-23) it seems that we used Rambal et al (2004) to estimate  $R_g$  and then  $R_m$  from  $R_{eco}$ ; but later (in page 16, lines 14-28) it appears we sum up  $R_{aa}$  and  $R_{ab}$ .

In order to make clearer the steps we have followed to obtain  $R_a$ , ( $R_h$ ),  $R_{aa}$ , ( $R_{leaf}$ ,  $R_{astem}$ ),  $R_{ab}$  and other fluxes, and also how we have combined the different fluxes to get the CUE, we draw the following figure. In this figure (Figure 2) we separated stand scale fluxes (grey), fluxes measured punctually at the organ or soil levels and up-scaled to the stand level (brown), and punctual biomass estimates (green). We suggest putting this graph as an appendix.

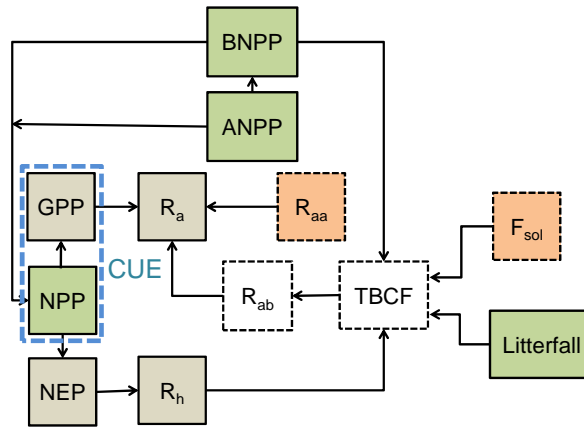

Figure 2. Method used in closing the whole-ecosystem carbon balance. Arrows are the information lines. The grey boxes surrounded by a continuous line are the ecosystem scale flux measurements yielding NEP, GPP and  $R_{eco}$  values. The green boxes are the continuous biometric measurements of the growth components. The boxes surrounded by a dashed line mean discrete measurements. The brown boxes are for discrete measurements of fluxes (leaf, stem and soil) up-scaled in time and space.

Stauch, V. J., Jarvis, A. J., & Schulz, K. (2008). Estimation of net carbon exchange using eddy covariance  $CO_2$  flux observations and a stochastic model. *Journal of Geophysical Research: Atmospheres (1984–2012)*, 113(D3).

3. *Carry-over effect of NPP on CUE* The author used different years' GPP, NPP, and soil water stress index to show the relationship between CUE and WSI. But as the authors said "The leaf production was not related to the current year WSI but to the previous year WSI" (line 10, page 8690), the CUE is partly determined by last year's GPP and NPP. So, there are must be some carry-over effects on the estimation of CUE, which would bias the relationship between CUE and WSI. This should be discussed.

The insensitivity of  $ANPP_{leaf}$  to current-year WSI alters NPP sensitivity to current-year WSI. In a wet year following a drier year,  $ANPP_{leaf}$  would be lower than expected by current climate. NPP may decline, but GPP too (and CUE?). We think in a wet year following a drier one, CUE could decline because  $ANPP_{stem}$  would be ruled by current climate and would be high as corresponds to a wet year, while leaves would be produced in less amount due to past-year drought carry-over effect on leaf number; the ratio of photosynthetic to non-photosynthetic tissue would decline and CUE could decline. Perhaps the strategy of holm oak to buffer the hydraulic system from climatic extremes has a penalty on CUE.

In other words, current-year drought causes GPP and less so  $R_a$  to decline, so that CUE declines slightly. If the previous year was drier, CUE could be lower than if the previous year was wet, because of the one-year-lag effect of drought on leaf production, but still, CUE will decline (slightly) due to current-year drought effects on leaf photosynthesis and less so plant respiration.

***Minor concerns:***

1. *Line 14, page 8681 “water stress integral (WSI)” may be just called “water stress index”.*

We do not agree. We prefer to continue using the term first proposed by Myers (1988) as water stress integral, with the same meaning.

4. *Line 17, page 8682 “LMA”. Define it before using.*

Ok we have detailed it.

5. *Lines 18\_20, page 8683: “They found annual fine root production”: This sentence is confusing. It’s leaf/root or root/leaf?*

They found annual fine root production over the 0-60 cm soil layer was quasi identical to the annual leaf production and found a ratio of fine root/leaf production of 1.04. We corrected this value to consider fine roots production over the whole profile (4.5m), by considering (i) the distribution of fine roots over the soil profile proposed by Jackson et al. (1997) for sclerophyllous shrubs and trees, and (ii) the increase of fine root turnover rate with depth (López et al., 2001). We obtained a ratio of fine root/leaf production of 1.25.

6. *Lines 17\_25, page 8685 and elsewhere: The authors presented the “CV” of some data. I’m just wondering what “CV” can tell the readers. I think it’s just represent “inter-annual variations” of these variables.*

Yes, it is between-year variation.

7. Line 25, page 8690: Fig. 6 should be Fig. 5

Corrected

8. Fig. 1 GPP and NEP. I'd like to see NPP in this figure.

We choose to plot first data coming from the eddy tower

9. Fig. 6 curve  $R_a/GPP$ . Since CUE ( $NPP/GPP$ ) has been shown in figure 5, it's not necessary to present  $R_a/GPP$ . To me, the figure is redundant.

There exist some redundancies between both figures. We agree but we wished to maintain this figure because some literature results used  $R_a/GPP$  rather than CUE.

Fig. A2. I'd like to see a curve of LAI vs. WSI?

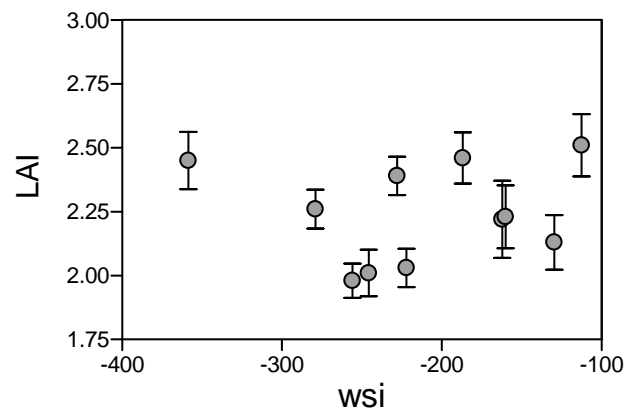

Figure 3. Relationship between WSI and LAI. This relationship is not significant.