

Effects of CO₂-driven ocean acidification on early life stages of Marine Medaka (*Oryziasmelastigma*)

Jingli Mu^a, FeiJin^a, JuyingWang^{a*}, NanZheng^a, Yi Cong^a

^aDivision of Marine Chemistry, National Marine Environmental Monitoring Center, Dalian 116023, China.

* Address correspondence to jywang@nmemc.org.cn (J.Y. Wang)

1 **Abstract**

2 The potential effects of elevated CO₂ level and reduced carbonate saturation state in
3 marine environment on fishes and other non-calcified organisms are still poorly
4 known. In present study, we investigated the responses of early life stages of marine
5 medaka (*Oryzias melastigma*) exposed to a series of experimental manipulation of
6 CO₂ levels. Results showed that CO₂-driven seawater acidification (pH 7.6 and pH 7.2)
7 had no detectable effect on hatching time, hatching rate, or heart rate of embryos.
8 However, the deformity rate of larvae in pH 7.2 treatment was significantly higher
9 than that in control treatment. The left and right otolith areas did not differ
10 significantly from each other in each treatment. However, the average otolith area of
11 larvae in pH 7.6 treatment was significantly smaller than that in the control. **The**
12 **alterations in the developmental abnormalities and otolith size of marine medaka**
13 **larvae due to elevated-CO₂ levels suggests that this species will be increasingly**
14 **challenged by future ocean acidification. Further studies of the impacts of ocean**
15 **acidification on marine fish to assess whether or not the environmental influence in**
16 **one generation can affect the later life history and the phenotype of subsequent**
17 **generations are needed.**

18 **Keywords:** climate change, non-calcified organisms, marine fish, early life stage,
19 otolith, calcification

20 1. Introduction

21 In the last century, the concentration of carbon dioxide (CO₂) released into
22 atmosphere continued to increase as a result of fossil fuel combustion and human
23 activities, which was in turn taken up by the ocean gradually through air-sea exchange.
24 Oceanic CO₂ can hydrolyze to increase the concentration of hydrogen ions (H⁺),
25 which leads to the reduction of pH in the ocean by 0.1 units(Orr et al., 2005). Based
26 on the amount of global CO₂ emission at present, the pH of ocean is likely to drop by
27 0.3 ~ 0.4 units by the end of the century and by 0.7 units after 300 years. The current
28 and predicted levels of CO₂ and acidity of seawater of nearshore, estuarine, and
29 higher-latitude habitats are expected to be even greater and substantially more
30 variable than those of the open ocean (Gruber et al., 2012; Zhai et al., 2014). **One**
31 **alarming consequence is a rapid change in seawater chemistry and decrease of ocean**
32 **pH, which could have great impacts on marine ecosystems, and pose a threat to**
33 **marine life (Frommel et al., 2013a; Kerr, 2010). Elevated CO₂ concentrations can**
34 **disturb the acid-base regulation, blood circulation, respiration, as well as the nervous**
35 **system of marine organisms, leading to long-term effects such as reduced growth rates**
36 **and reproduction (Frommel et al., 2013a). Other directs of ocean acidification have**
37 **been found in the alteration of behavior (Dixson et al., 2010; Munday et al., 2009a),**
38 **development (Frommel et al., 2012b), RNA/DNA ratio (Franke and Clemmesen,**
39 **2011), and otholiths (Checkley et al., 2009; Maneja et al., 2013; Munday et al., 2011b)**
40 **of marine fish larvae. However, the emerging picture remains intriguingly complex.**
41 **While the majority of responses to high CO₂ appear to be negative (Branch et al.,**
42 **2013) with highest sensitivities observed during the early life stages and in calcifying**
43 **invertebrates such as corals, bivalves, pteropods, and echinoderms, there are also**
44 **substantial evidences for non-linear, neutral, or even positive reaction to increasing**
45 **CO₂ conditions (Hurst et al., 2013; Munday et al., 2011b; Murray et al., 2014).**
46 **Moreover, marine fish exemplify this complexity. Decades of empirical data suggest**
47 **that juvenile and adult fish possess sufficient acid-base and osmoregulatory**
48 **capabilities for the toleration of very high metabolic and ambient CO₂ levels (> 2000**

49 μatm) (Murray et al., 2014). Although fish possesses the ability of acid-base balance
50 regulation, its physiological function will certainly decline under such regulation for a
51 long time from the perspective of energetics, especially in the most fragile and
52 sensitive early life stage during its life history. In addition, in early life stages of
53 multiple taxa including fish, elevated CO_2 was shown to affect calcification of shells
54 and skeletons due to a drop in the carbonate availability (Riebesell, et al., 2010).
55 Munday et al. (2011a) observed no effect on spiny damselfish otolith calcification at
56 $850 \mu\text{atm}$, while Munday et al. (2011b) and Checkley et al. (2009) highlighted an
57 otolith hypercalcification in white seabass (*Atractoscion nobilis*) larvae exposed at
58 $993 \mu\text{atm}$ and $2558 \mu\text{atm } p\text{CO}_2$ and in clownfish (*Pomacentridae*) larvae at $1721 \mu\text{atm}$
59 $p\text{CO}_2$, respectively. In case of calcification modulation, otolith morphology can be
60 affected, which may have negative repercussions on the behavior and acoustic function
61 of fish and decrease their survival probabilities (Bignami et al., 2013; Réveillac et al.,
62 2015).

63 Marine medaka, *Oryzias melastigma* or *Oryzias javanicus*, is one of the 14 species
64 belonging to the genus *Oryzias*, which distribute in estuarine waters from East to
65 Southeast Asia (Koyama et al., 2008). It has been proposed as a model species in
66 marine environmental risk assessments (Mu et al., 2014). However, few studies have
67 addressed OA effects on the early life stages (ELS) of marine medaka so far. The
68 objective of this study was to examine how CO_2 -driven ocean acidification affect the
69 embryos and newly hatched larvae of marine medaka after 21 d exposure through
70 investigating embryonic development, larval development, and otolith development.

71 **2. Materials and methods**

72 **2.1 Fish rearing**

73 Marine medaka, *O. melastigma*, were provided by the Key Laboratory of Coastal
74 Ecological Environment of State Oceanic Administration. Fish were maintained in
75 aquatic habitats system (Aquatic Habitats, USA) with a salinity of 30 ± 2 , temperature
76 of $26 \pm 1 \text{ }^\circ\text{C}$, and a photoperiod of 14 h:10 h (light:dark). All fishes were fed with
77 nauplii of *Artemia* three times a day and synthetic food (New life spectrum thera-A

78 formula, Made in the Newlife International, Inc, USA.) twice a day. One-tenth of the
79 total amount of water in the system was automatically renewed daily. To ensure
80 developmental synchronization of embryos during experiment, all eggs were collected
81 within 3 ~ 5 h after initiation of spawning, and fertilized and viable ones were
82 selected under dissecting microscope.

83 The experimental seawater (salinity of 30.7 ± 0.1) was prepared by diluting sea
84 salts (Instant Ocean, Aquarium Systems, USA) with deionized water. The standard
85 NBS pH was 8.2 ± 0.004 .

86 **2.2 Seawater manipulation and experimental design**

87 The design of seawater pH control system was based on Riebesell et al.(Riebesell,
88 et al., 2010) with some modifications. Briefly, partial pressure of CO₂ ($p\text{CO}_2$) was
89 adjusted by pH modulator (aquastar pH Modul II, IKS) with standard deviation of
90 ± 0.01 . Three pH gradients, 8.2, 7.6 and 7.2, were set according to the predicted levels
91 upon CO₂ emission at present, after 100 and 300 years (Orr et al., 2005), respectively.
92 The pH control system **consists of** three parts, namely monitor, controller and aeration
93 (Fig. 1). The pH meter in water **monitored** real-time pH changes during experiment.
94 The controller associated with pH meter **was also connected with** electromagnetic
95 valve, which **opened or closed** the electromagnetic valve according to the feedback of
96 pH meter. The intake of electromagnetic valve **connected** to a cylinder equipped with
97 a high concentration of CO₂(0.1 % CO₂: 99.9 % air, $p\text{CO}_2$ of 1000 ppm), and its
98 outtake **connected** to silicone tube, drying tube, check valve and refiner which insert
99 into seawater. The refiner was placed in the middle of the aquarium (10 L) bottom to
100 make the gas bubbled into water quickly and homogeneously. When the pH in
101 seawater was higher than the set value, electromagnetic valve **opened** automatically to
102 pipe **concentrated** CO₂ into the water until the pH drop to the set value, and then the
103 valve closed. During the exposure experiment, parameters including pH, inorganic
104 carbon (DIC), temperature, salinity, total alkalinity (TA) and dissolved oxygen (DO)
105 were continuously monitored and analyzed to ensure the stability of pH control
106 system.

107 **For each pH treatment, 90 fertilized eggs were randomly assigned to three tanks**

108 (three replicates) with 30 ones per replicate. These tanks were monitored daily for
109 dead embryos, hatched larvae, and hatching time. Subsets of hatched larvae per tank
110 were then transferred to the alternative aquariums with the same exposure conditions
111 to start the larval exposure sub-experiment (3 CO₂ levels × 3 replicates). Larvae were
112 monitored daily and dead ones were removed until the termination of experiment at
113 21 days (approximately one-week post-hatch). By the end of experiments, the survival
114 larvae were anesthetized and photographed under microscope (Leica DMI4000B) for
115 deformity analyses, and the otoliths were then removed and dry-stored in well-plates.

116 **[Figure.1]**

117 **2.3 Determination of Water Quality Parameters**

118 The determination of pH, TA and DIC referred to the methods of Dickson et al.
119 (2007). In brief, samples were collected into vials without obvious bubbles by an
120 overflow manner, and then fixed with 0.1 % saturated HgCl₂ solution. The pH was
121 detected using combined electrode (Orion 8102 BN Ross) and high-precision pH
122 meter (Thermo Orion 3-Star, USA) in 25°C water bath within 2 h after sampling. The
123 deviation was less than 0.01. TA and DIC were detected by TA analyzer (Apollo
124 AS-ALK2, USA) and DIC analyzer (Apollo AS-C3, USA) with an accuracy of more
125 than ± 2 μmol/kg, respectively. Salinity, temperature and DO of seawater were
126 detected by YSI-85 water quality monitor (YSI Inc, USA), and the accuracy of each
127 parameter was more than ± 0.1 ppt, ± 0.1 °C and ± 2% air saturation, respectively.
128 Aragonite saturation (Ω_{Ar}) was calculated based on temperature, salinity and measured
129 TA and DIC through CO₂-SYS carbonate system software (Pelletier et al., 2011).
130 Other parameters adoption including dissociation constants of carbonic acid and
131 sulfuric acid, saturated solubility product of CaCO₃ were consistent with those
132 internationally applied (Millero et al., 2006).

133 **2.4 Developmental toxicity**

134 The numbers of embryos surviving to hatching were counted based on daily
135 inspection of the embryos in each treatment. Hatching rate data were summed and

136 converted to proportions of survival numbers out of 30 eggs in per replicate. After 8
137 days post fertilization, and 3 days before expected hatching, embryos were inspected
138 at least twice a day to record hatching numbers. Estimates of heart rate were
139 completed by counting the number of heart beats over a 30 s period ($n = 10$) at day 8.
140 The time when ≥ 50 % of the embryos had hatched was recorded as "hatching time"
141 (Forsgren et al., 2013). As observations of spawning and hatching were made at
142 somewhat irregular intervals over the course of the study, spawning and hatching
143 times were analyzed. The embryonic hatching time was calculated as the time elapsed
144 between spawning and hatching.

145 On day 21, thirty larvae (10 larvae per replicate) from each CO₂ treatment were
146 randomly selected and photographed for deformity analyses. The deformity rate were
147 calculated based on the proportions of abnormal larvae numbers out of 10 eggs in per
148 replicate. Survival rate of larvae was the obtained proportions through dividing the
149 larvae numbers remaining at termination of the experiment by the larvae numbers
150 initially newly hatched in per replicate.

151 **2.5 Otolith measurement**

152 The measurement of marine medaka otolith was based on the method of Franke
153 and Clemmesen (2011). Briefly, the left and right otoliths were removed from 16 fish
154 larvae randomly selected from each CO₂ treatment. Each otolith was observed and
155 photographed under microscope (Leica DMI4000B). Digital pictures of otolith were
156 taken at 1000 \times magnification using the microscope equipped with Leica DFC420C
157 Digital Camera. Otolitharea (μm^2) was calculated through Image-Pro Plus 5.0
158 software after calibration and gray-scale processing of photos.

159 **2.6 Statistical Analyses**

160 Data analyses were performed using SPSS ver.16.0 (Chicago, IL) software. All
161 data were tested for normal distribution using the Kolmogorov-Smirnov test.
162 Non-normally distributed data were log-transformed. The difference between
163 measured and nominal pH was analyzed by T-test. For heart rate, hatching rate,
164 hatching time, and deformity rate, one-way analysis of variance (ANOVA) followed
165 by Bonferroni post hoc tests were applied to test the differences between and among

166 groups. An independent sample test was used to compare the difference of otolith
167 areas between left and right sides in each treatment. If there was a significant
168 difference, one-way ANOVA was used to further compare the difference between
169 treatments for left and right sides, respectively. If not, one-way ANOVA was
170 performed after data combining of left and right sides. Results were expressed as
171 means \pm standard deviation (SD).

172 **3. Results**

173 **3.1 Seawater chemical parameters**

174 Measured pH in three treatments and different chemical parameters in seawater
175 were shown in Figure 2 and Table 1, respectively. During the 21 d of exposure,
176 measured pH in pH 8.2, 7.6 and 7.2 groups were 8.22 ± 0.004 , 7.63 ± 0.007 and 7.22
177 ± 0.002 , respectively. The fluctuation was less than 0.05 (Fig.2), indicating the
178 stability of pH control system.

179 [Figure 2.]

180 [Table 1.]

181 **3.2 Embryonic development**

182 Three replicates produced a total of 90 eggs in each CO₂ treatment. The hatching
183 times were extended with decreasing pH level, but there was no significant difference
184 among the three pH treatments ($F_{2,6} = 5.8$, $p = 0.066$) (Fig. 3A). On average, 83
185 percent of eggs in three pH treatments survived to hatch, and the hatching rate of eggs
186 was not significantly different among the three pH treatments ($F_{2,6} = 1.1$, $p = 0.4$) (Fig.
187 3B). For the heart rates of embryos, pH 7.6 and 7.2 groups were not significantly
188 different from those in the control group ($F_{2,28} = 1.7$, $p = 0.7$) (Fig. 3C).

189 [Figure 3.]

190 **3.3 Larval development**

191 Three replicates produced a total of 66 ~75 newly hatched larvae in each CO₂
192 treatment level. By the end of experiment, larvae survival rate was highly variable but
193 did not differ significantly between the control and acidified water groups ($F_{2,6} = 0.3$,

194 $p=0.7$) (Fig. 4B).

195 However, the two lower pH treatments (pH 7.6 and pH 7.2) can both cause spinal
196 deformities, craniofacial deformities, stretched heart and pericardial edema of marine
197 medaka larvae (Fig.5). Furthermore, in pH 7.2 treatment, the deformity rate was
198 significantly higher than that of control group ($F_{1,4} = 32, p=0.005$) (Fig. 4A).

199 [Figure 4.]

200 [Figure 5.]

201 3.4 Otolith development of larvae

202 The effects of different pH treatments on otolith size of marine medaka larvae
203 were shown in Figure 6. There were no statistically significant difference between the
204 areas of left and right sides in each pH treatment (pH 8.2: $F_{1,59} = 0.092, p = 0.76$; pH
205 7.6: $F_{1,67} = 0.045, p = 0.83$; pH 7.2: $F_{1,68} = 0.005, p = 0.95$, respectively) (Fig. 6A). In
206 pH 7.6 treatment, the average areas of left and right sides were significantly smaller
207 than those of the control treatment ($F_{1,128} = 8.8, p = 0.013$) (Fig. 6B).

208 [Figure 6.]

209 4. Discussions

210 Assessment of species sensitivity or tolerance to CO₂-driven acidification in
211 marine environment is critical to evaluate the impacts of OA on marine biodiversity
212 and ecosystem function (Fabry et al., 2008; Melzner et al., 2009). A number of studies
213 found that CO₂-driven acidification had obvious influences on early life stages of
214 many marine invertebrates, especially calcified organisms including coral
215 (Doropoulos et al., 2012; Fabricius et al., 2011), **coccolithophores** (Berry et al., 2002),
216 and mollusk (Kroeker et al., 2013; Thomsen et al., 2013; Waldbusser et al., 2011). OA
217 was predicted to potentially affect individual behavior such as development, growth,
218 survival and swimming particularly during the early life stage of marine organisms
219 (Munday et al., 2008). In our experiments, the duration of embryonic stage, egg
220 survival and embryonic heart rate of marine medaka were unaffected by acidification

221 water with pH 7.6 and pH 7.2. There was a slight increase in embryonic duration of
222 eggs, but the size effect was not different among the three pH treatments. Overall,
223 these results suggest that the egg stage of marine medaka is relatively tolerant to
224 elevated CO₂ and low pH level, which were consistent with the results reported by
225 other studies on a diverse set of marine fishes. For instance, Munday et al., (2009)
226 found the survival to hatch of orange clownfish (*Amphiprion percula*) from the Great
227 Barrier Reef, Australia, to be nonresponsive to pCO₂ levels to 1020 ppm (pH 7.8).
228 Similarly, Franke and Clemmesen (2012) found no significant effect of elevated pCO₂
229 levels from 460 to 4635 ppm (corresponding to pH 8.08 ~ pH 7.05) on survival to
230 hatch of Atlantic herring from the western Baltic Sea. In the study of Frommel et al.
231 (2013), the survival of embryos of Atlantic cod from the Bornholm Basin of the
232 western Baltic Sea was not altered at pCO₂ levels up to 4000 ppm (pH 7.2). Hurst et al.
233 (2013) also reported no effect on embryo survival of walleye pollock (*Theragra*
234 *chalcogramma*), common in the temperate eastern North Pacific, at pCO₂ levels up to
235 1933 ppm (pH 7.4). In other cases, however, a strong effect of CO₂ was observed
236 evident in the embryo survival of summer flounder (*Paralichthys dentatus*), an
237 ecologically and economically important flatfish of the inshore and nearshore waters
238 of the Mid-Atlantic Bight (Chambers et al., 2013). The relative survival of summer
239 flounder embryos was reduced to 48% when maintained at 1808 ppm pCO₂ (pH 7.5)
240 and to 16% when maintained at 4714 ppm pCO₂ (pH 7.1). Baumann et al. (2012) also
241 reported a 74% reduction in survival of embryos and young larvae of inland silverside,
242 *Menidia beryllina*, native to estuaries of the US Atlantic coast, when maintained at
243 1100 ppm pCO₂ compared to those held at 410 ppm pCO₂. All of these studies varied
244 in the number of parents used, the time lapse between egg fertilization and the
245 initiation of the CO₂ treatment, and in how and when survival was scored. For
246 example, the CO₂ treatments of inland silverside by Baumann et al. (2012) began at
247 approximately 24 h post-fertilization, and the survival was scored at approximately 1
248 week post-hatching. The different approaches used among previous studies may
249 preclude a fair cross-study comparison (Chambers et al., 2014), however, the overall
250 present of effect of elevated CO₂ environments on embryo survival is in contrast to

251 the findings here. The habitats occupied by a species, particularly its ELS, may play a
252 role in their sensitivities whose ELS are found in estuarine (marine medaka) or inner
253 shelf (summer flounder) habitats, both with relatively high ambient CO₂ levels,
254 exhibit different sensitivity to experimentally elevated-CO₂ levels is counter to
255 expectations and requires further attention.

256 An unexpected result of our study was that elevated levels of CO₂ affected larval
257 development abnormalities, and the average deformity rate of marine medaka larvae
258 (approximately one-week post-hatch) increased significantly by 16 % as CO₂
259 increased from control level (pH 8.2) to high-CO₂ level (pH 7.2). Although
260 CO₂-induced acidification up to the high-CO₂ level (pH 7.2) had no noticeable effect
261 on larval survival by the end of experiments (21 d), the larval development
262 abnormalities may ultimately influence the later life consequences and therefore
263 further reduce the productivity of fish stock in future acidified oceans. Chambers et al.
264 (2014) found no reduction in survival with CO₂ for larvae during the first four weeks
265 of larval life (experiment ended at 28 d post-hatching (dph)), however, the sizes,
266 shapes, and developmental status of larvae showed initially longer and faster growing
267 when reared at pH 7.5 and pH 7.1 levels, and the tissue damage was evident in larvae
268 as early as 7 dph from both elevated-CO₂ levels. At present, it is unknown that how
269 increasing CO₂ levels affect development and survival in fish early life stages. Even if
270 fish embryos and early larvae are capable of physiological adaptation to increased
271 CO₂ somehow, this would incur further metabolic costs and thus reduce energy
272 available for tissue synthesis or post-hatch survival on diminished yolk reserves. As
273 some fish eggs, including those of *O. melastigma*, seem to be tolerant to low-pH
274 conditions, the high levels of CO₂ or associated changes in carbonate chemistry may
275 be more important to larval-fish development than hydrogen ion concentrations.
276 (Baumann et al., 2011; Ishimatsu et al., 2008).

277 The pH drop driven by CO₂ can change concentrations of bicarbonate and
278 non-bicarbonate ions during which elevated CO₂ affects saturation states of calcium
279 ions carbonate polymorphs (Munday et al., 2008). Otoliths are bony structures of fish
280 to sense orientation and acceleration and consist of aragonite-protein bilayers, which

281 document fish age and growth (Checkley et al., 2009). Its formation starts during
282 embryonic development, and any alteration of otolith size or shape is important for
283 physical performance and individual adaptability of fish. Therefore, any substantial
284 change in the size, shape, or symmetry of otoliths could have serious implications for
285 individual performance and survival (Munday et al., 2011a; Munday et al., 2008). In
286 this study, we found no significant difference existing between the left and right sides
287 of marine medaka larval otolith under the same pH level. However, otolith area of
288 larval fish exposed to the intermediate-CO₂ level (pH 7.6) was smaller than that of
289 control. Results suggested that there was no significant pCO₂ effect on otolith
290 symmetry of marine medaka, defined as the difference between the right and left sides.
291 However, the otolith area was significantly affected. The trend of reduction in otolith
292 area of marine medaka larvae exposed to elevated CO₂ environments found here has
293 not been reported by most previous authors whose studies focused on other marine
294 fishes. For instance, Checkley et al. (2009) found that otolith area of white seabass
295 (*Atractoscion nobilis*) larvae increased by 7% ~ 9% and 10% ~ 14% after exposure to
296 993 ppm and 2558 ppm CO₂, respectively. Munday et al. (2011b) found that the size,
297 shape, and symmetry of otoliths in larval clowfish was unaffected by exposure to
298 simulated levels of ocean acidification (pH 7.8 and 1050 μatm CO₂); however, in a
299 more extreme treatment (pH 7.6 and 1721 μatm CO₂) otolith area and maximum
300 length were larger than those of control otoliths. Maneja et al.(2013) found that
301 elevated CO₂ had no significant effect on the shape of the otoliths nor was there any
302 trend in the fluctuating asymmetry, while increased otolith growth was observed in 7
303 to 46 d post hatch cod larvae in two pCO₂ treatments of 1800 μatm and 4200 μatm. In
304 contrast, Munday et al. (2011a) did not detect any effect of elevated CO₂ on otolith
305 size of juvenile spiny damselfish, *Acanthochromis polyacanthus*, which were reared
306 for 3 weeks in treatments up to 841 μatm CO₂. Our results seemed to support the
307 hypothesis that otoliths of larvae reared in seawater with elevated CO₂ would grow
308 more slowly than they do in seawater with normal CO₂. The reduction of otolith area
309 was likely associated with reduced saturation of CaCO₃ which slowed down its
310 formation. We do not know whether smaller otoliths have a deleterious effect,

311 although we do know that asymmetry between otoliths can be harmful (Checkley et
312 al., 2009). The difference between our results and other studies may be related to: (1)
313 different $p\text{CO}_2$ levels; (2) different life histories; or (3) different exposure duration.
314 However, another interesting result from the present study was that the otolith area of
315 marine medaka larvae under the extreme CO_2 level (pH 7.2) tended to increase
316 instead of continuously reducing. This should not ignore its own acid-base regulation
317 ability that increased the available amount of carbonate by compensation mechanism
318 for otolith to intensify the calcification process under such acidic condition (Checkley
319 et al., 2009). Calcium incorporation into the otolith was modulated by the seawater
320 pH. This question the stability of the elemental: Ca ratio under environmental
321 hypercapnia. During the biomineralization of the otolith, chemical elements such as
322 metals and metalloids are supposed to substitute for calcium (Réveillac et al., 2015).
323 The changes of pH and seawater chemistry caused by increased CO_2 can modify the
324 speciation of metals and their subsequent bioavailability to organisms (Millero et al.,
325 2006). The physiological response of fish to hypercapnia might in turn stimulate
326 processes to compensate for acidosis based on the key role of ion transporters. In
327 present study, ocean acidification may interfere with trace element uptake and body
328 concentrations and therefore could affect otolith growth and microchemical
329 constituent. Further studies are thus needed to investigate the possibility that ocean
330 acidification impacts on the trace metals properties, molecular-binding affinities and
331 incorporation pathway into the otolith.

332 In conclusion, this study demonstrated that, under projected near-future $p\text{CO}_2$
333 levels, the early life stages of marine medaka exhibited a dramatic increase of larval
334 developmental deformity and otolith calcification while their survival was not
335 affected. Importantly, the observed CO_2 -induced abnormal development of larvae
336 might have predictably negative consequences on the recruitment of fish population,
337 the effects of which on later life history and the phenotype of subsequent generations
338 of ocean acidification on marine fish should be concerned. As the otolith is an
339 essential tool used in reconstructing fish life history in terms of age, somatic growth
340 and attended habitats, further studies should investigate the process of otolith

341 biomineralization. Finally, we emphasize that there is considerable variation among
342 species in their sensitivity to elevated CO₂ and reduced pH. Determining the traits that
343 render some species more susceptible than others will be helpful and valuable to
344 predict the long-term and ecological effects of ocean acidification.

345 **Acknowledgement**

346 This study was financially supported by the National Natural Science Foundation
347 of China (No.41476096 and No.41106089), and the Key Laboratory Fund of
348 Ecological Environment in Coastal Areas, State Oceanic Administration (No. 201202).
349 We thank Dr. Xuemei Xu and Prof. Weidong Zhai of National Marine Environmental
350 Monitoring Center for their suggestions on experimental design and calculation in
351 carbonate system.

352 **References**

- 353 Baumann, H., Talmage, S. C., and Gobler, C. J.: Reduced early life growth and
354 survival in a fish in direct response to increased carbon dioxide, *Nature Clim.*
355 *Change*, 2, 38-41, 2012.
- 356 Berry, L., Taylor, A. R., Lucken, U., Ryan, K. P., and Brownlee, C.: Calcification and
357 inorganic carbon acquisition in coccolithophores, *Functional Plant Biology*, 29,
358 289-299, 2002.
- 359 Bignami, S., Sponaugle, S., and Cowen, R. K.: Response to ocean acidification in
360 larvae of a large tropical marine fish, *Rachycentron canadum*, *Global Change*
361 *Biology*, 19, 996-1006, 2013.
- 362 Branch, T. A., DeJoseph, B. M., Ray, L. J., and Wagner, C. A.: Impacts of ocean
363 acidification on marine seafood, *Trends in ecology & evolution*, 28, 178-186, 2013.
- 364 Chambers, R. C., Candelmo, A. C., Habeck, E. A., Poach, M. E., Wiczorek, D.,
365 Cooper, K. R., Greenfield, C. E., and Phelan, B. A.: Effects of elevated CO₂ in the
366 early life stages of summer flounder, *Paralichthys dentatus*, and potential
367 consequences of ocean acidification, *Biogeosciences*, 11, 1613-1626, 2014.
- 368 Checkley, D. M., Dickson, A. G., Takahashi, M., Radich, J. A., Eisenkolb, N., and
369 Asch, R.: Elevated CO₂ Enhances Otolith Growth in Young Fish, *Science*, 324,
370 1683, 2009.
- 371 Dickson, A. G., Sabine, C. L., and Christian, J. R.: Guide to best practices for ocean
372 CO₂ measurements., North Pacific Marine Science Organization (PICES), Sidney,
373 British Columbia, 2007.
- 374 Dixson, D. L., Munday, P. L., and Jones, G. P.: Ocean acidification disrupts the innate
375 ability of fish to detect predator olfactory cues, *Ecology Letters*, 13, 68-75, 2010.
- 376 Doropoulos, C., Ward, S., Diaz-Pulido, G., Hoegh-Guldberg, O., and Mumby, P. J.:
377 Ocean acidification reduces coral recruitment by disrupting intimate larval-algal
378 settlement interactions, *Ecology Letters*, 15, 338-346, 2012.
- 379 Fabricius, K. E., Langdon, C., Uthicke, S., Humphrey, C., Noonan, S., De'ath, G.,
380 Okazaki, R., Muehlllehner, N., Glas, M. S., and Lough, J. M.: Losers and winners
381 in coral reefs acclimatized to elevated carbon dioxide concentrations, *Nature Clim.*
382 *Change*, 1, 165-169, 2011.
- 383 Forsgren, E., Dupont, S., Jutfelt, F., and Amundsen, T.: Elevated CO₂ affects
384 embryonic development and larval phototaxis in a temperate marine fish, *Ecology*
385 *and Evolution*, 3, 3637-3646, 2013.
- 386 Franke, A. and Clemmesen, C.: Effect of ocean acidification on early life stages of
387 Atlantic herring (*Clupea harengus L.*), *Biogeosciences*, 8, 3697-3707, 2011.
- 388 Frommel, A. Y., Maneja, R., Lowe, D., Malzahn, A. M., Geffen, A. J., Folkvord, A.,

389 Piatkowski, U., Reusch, T. B. H., and Clemmesen, C.: Severe tissue damage in
390 Atlantic cod larvae under increasing ocean acidification, *Nature Clim. Change*, 2,
391 42-46, 2012a.

392 Frommel, A. Y., Schubert, A., Piatkowski, U., and Clemmesen, C.: Egg and early
393 larval stages of Baltic cod, *Gadus morhua*, are robust to high levels of ocean
394 acidification, *Marine Biology*, 160, 1825-1834, 2013b.

395 Gruber, N., Hauri, C., Lachkar, Z., Loher, D., Frölicher, T. L., and Plattner, G.-K.:
396 Rapid Progression of Ocean Acidification in the California Current System,
397 *Science*, 337, 220-223, 2012.

398 Hurst, T. P., Fernandez, E. R., and Mathis, J. T.: Effects of ocean acidification on
399 hatch size and larval growth of walleye pollock (*Theragra chalcogramma*), *ICES*
400 *Journal of Marine Science: Journal du Conseil*, 70, 812-822, 2013.

401 Ishimatsu, A., Hayashi, M., and Kikkawa, T.: Fishes in high-CO₂, acidified oceans,
402 *Marine Ecology Progress Series*, 373, 295-302, 2008.

403 Kerr, R. A.: Ocean Acidification Unprecedented, Unsettling, *Science*, 328, 1500-1501,
404 2010.

405 Koyama, J., Kawamata, M., Imai, S., Fukunaga, M., Uno, S., and Kakuno, A.: Java
406 medaka: a proposed new marine test fish for ecotoxicology, *Environmental*
407 *toxicology*, 23, 487-491, 2008.

408 Kroeker, K. J., Kordas, R. L., Crim, R., Hendriks, I. E., Ramajo, L., Singh, G. S.,
409 Duarte, C. M., and Gattuso, J. P.: Impacts of ocean acidification on marine
410 organisms: quantifying sensitivities and interaction with warming, *Glob Chang*
411 *Biol*, 19, 1884-1896, 2013.

412 Maneja, R. H., Frommel, A. Y., Geffen, A. J., Folkvord, A., Piatkowski, U., Chang, M.
413 Y., and Clemmesen, C.: Effects of ocean acidification on the calcification of
414 otoliths of larval Atlantic cod *Gadus morhua*, *Marine Ecology Progress Series*, 477,
415 251-258, 2013.

416 Millero, F. J., Graham, T. B., Huang, F., Bustos-Serrano, H., and Pierrot, D.:
417 Dissociation constants of carbonic acid in seawater as a function of salinity and
418 temperature, *Marine Chemistry*, 100, 80-94, 2006.

419 Mu, J., Wang, J., Jin, F., Wang, X., and Hong, H.: Comparative embryotoxicity of
420 phenanthrene and alkyl-phenanthrene to marine medaka (*Oryzias melastigma*),
421 *Marine Pollution Bulletin*, 85, 505-515, 2014.

422 Munday, P. L., Dixon, D. L., Donelson, J. M., Jones, G. P., Pratchett, M. S., Devitsina,
423 G. V., and Døving, K. B.: Ocean acidification impairs olfactory discrimination and
424 homing ability of a marine fish, *Proceedings of the National Academy of Sciences*
425 *of the United States of America*, 106, 1848-1852, 2009a.

426 Munday, P. L., Donelson, J. M., Dixon, D. L., and Endo, G. G. K.: Effects of ocean

- 427 acidification on the early life history of a tropical marine fish, Proceedings of the
428 Royal Society B: Biological Sciences, 276, 3275-3283, 2009b.
- 429 Munday, P. L., Gagliano, M., Donelson, J. M., Dixson, D. L., and Thorrold, S. R.:
430 Ocean acidification does not affect the early life history development of a tropical
431 marine fish, Marine Ecology Progress Series, 423, 211-221, 2011a.
- 432 Munday, P. L., Hernaman, V., Dixson, D. L., and Thorrold, S. R.: Effect of ocean
433 acidification on otolith development in larvae of a tropical marine fish,
434 Biogeosciences 8, 1631-1641, 2011b.
- 435 Munday, P. L., Jones, G. P., Pratchett, M. S., and Williams, A. J.: Climate change and
436 the future for coral reef fishes, Fish and Fisheries, 9, 261-285, 2008.
- 437 Murray, C. S., Malvezzi, A., Gobler, C. J., and Baumann, H.: Offspring sensitivity to
438 ocean acidification changes seasonally in a coastal marine fish, Marine Ecology
439 Progress Series, 504, 1-11, 2014.
- 440 Orr, J. C., Fabry, V. J., Aumont, O., Bopp, L., Doney, S. C., Feely, R. A.,
441 Gnanadesikan, A., Gruber, N., Ishida, A., Joos, F., Key, R. M., Lindsay, K.,
442 Maier-Reimer, E., Matear, R., Monfray, P., Mouchet, A., Najjar, R. G., Plattner,
443 G.-K., Rodgers, K. B., Sabine, C. L., Sarmiento, J. L., Schlitzer, R., Slater, R. D.,
444 Totterdell, I. J., Weirig, M.-F., Yamanaka, Y., and Yool, A.: Anthropogenic ocean
445 acidification over the twenty-first century and its impact on calcifying organisms,
446 Nature, 437, 681-686, 2005.
- 447 Pelletier, G. J., Lewis, E., and Wallace, D. W. R.: CO2SYS.XLS:A calculator for the
448 CO2 system in seawater for Microsoft Excel/VBA, Ver. 16, Washington State
449 Department of Ecology, Olympia, Washington, 2011.
- 450 Réveillac, E., Lacoue-Labarthe, T., Oberhänsli, F., Teyssié J.-L., Jeffree, R., Gattuso,
451 J.-P., and Martin, S.: Ocean acidification reshapes the otolith-body allometry of
452 growth in juvenile sea bream, Journal of Experimental Marine Biology and
453 Ecology, 463, 87-94, 2015.
- 454 Riebesell U., Fabry, V. J., Hansson Lina., and Gattuso Jean-Pierre.: Guide to best
455 practices for ocean acidification research and data reporting., Publications office of
456 the European Union, Luxembourg, 258 pp., 2010.
- 457 Thomsen, J., Casties, I., Pansch, C., Körtzinger, A., and Melzner, F.: Food availability
458 outweighs ocean acidification effects in juvenile *Mytilus edulis*: laboratory and
459 field experiments, Global Change Biology, 19, 1017-1027, 2013.
- 460 Waldbusser, G., Voigt, E., Bergschneider, H., Green, M., and Newell, R. E.:
461 Biocalcification in the Eastern Oyster (*Crassostrea virginica*) in Relation to
462 Long-term Trends in Chesapeake Bay pH, Estuaries and Coasts, 34, 221-231,
463 2011.
- 464 Zhai, W. D., Zheng, N., Huo, C., Xu, Y., Zhao, H. D., Li, Y. W., Zang, K. P., Wang, J.
465 Y., and Xu, X. M.: Subsurface pH and carbonate saturation state of aragonite on the

466 Chinese side of the North Yellow Sea: seasonal variations and controls,
467 Biogeosciences, 11, 1103-1123, 2014.

468

469

470

471 **Table list**

472 **Table 1. Summary of chemical parameters in control and acidic seawater ($n = 3$)**

pH_{NBS}^*	DIC ($\mu\text{mol/kg}$)	$p\text{CO}_2$ (μatm)	CO_2 ($\mu\text{mol/kg}$)	HCO_3^- ($\mu\text{mol/kg}$)	CO_3^{2-} ($\mu\text{mol/kg}$)	Ω_{ar}
8.22 ± 0.004	2645.1 ± 28.5	495.9 ± 2.2	14.4 ± 0.1	2380.3 ± 10.1	280.4 ± 3.9	4.5 ± 0.06
7.63 ± 0.007	3014.2 ± 74.3	2372.6 ± 52.3	68.7 ± 1.4	2861.0 ± 20.7	84.5 ± 0.3	1.4 ± 0.006
7.22 ± 0.002	3202.7 ± 18.5	6165.7 ± 56.4	178.4 ± 1.8	2988.8 ± 9.3	35.5 ± 0.6	0.6 ± 0.01

473 * pH_{NBS} : The fundamental definition of pH in terms of the hydrogen ion activity; NBS: National Bureau
 474 of Standard.

475

476 **Figures and captions**

477

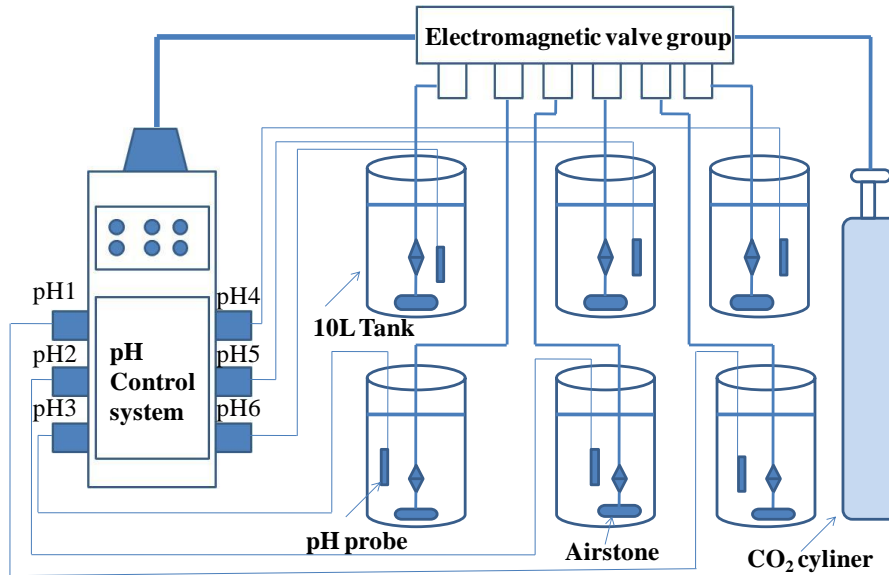

478

479 **Figure 1.**Schematic illustration of the pH control system applied in exposure experiment (For details refer
480 to the text).

481

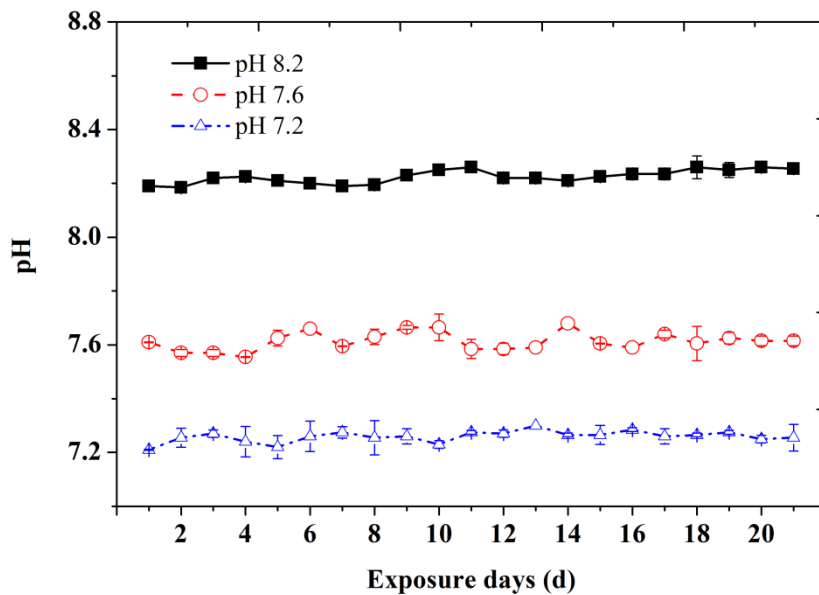

482

483 **Figure 2.** Measured mean pH_{NBS} of seawater in three pH treatments during 21 d of exposure ($n=3$).

484

485

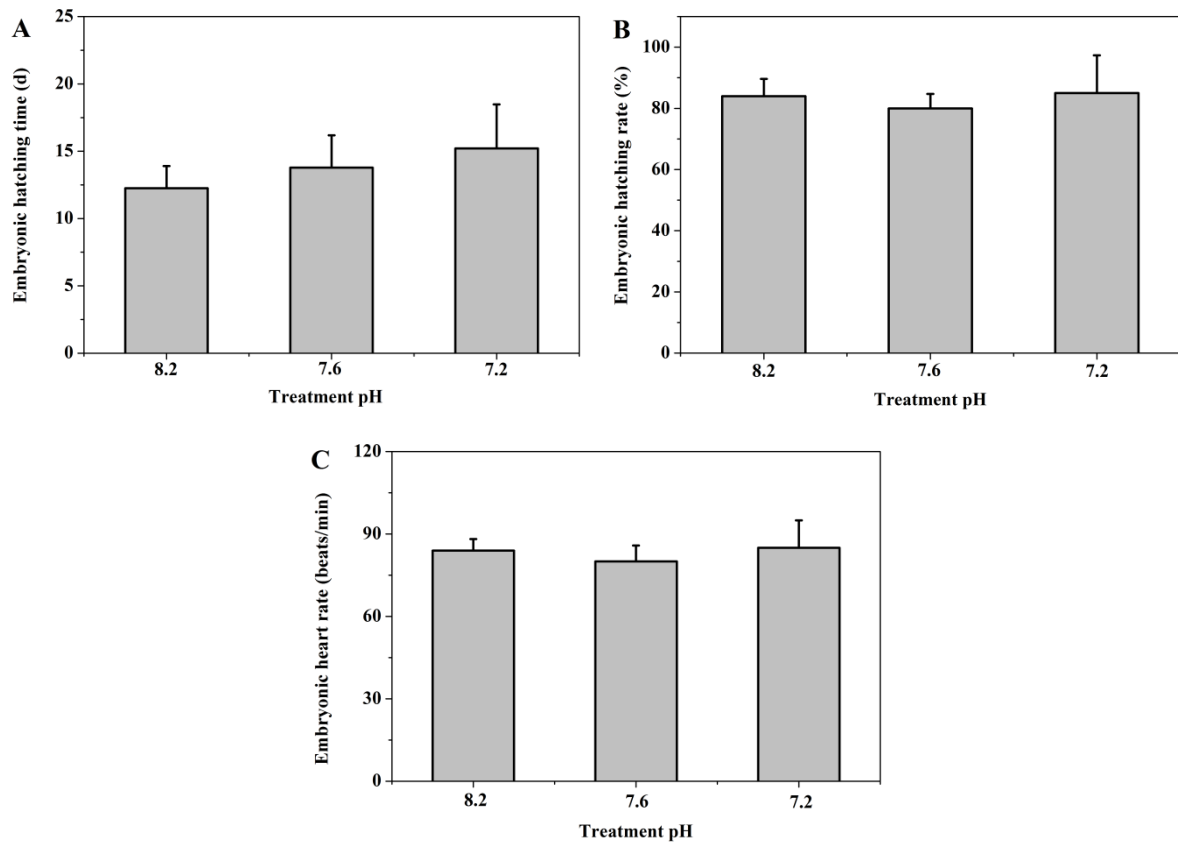

486

487

488 **Figure 3. The hatching time, hatching rate, and heart rate of marine medaka embryos exposed to three pH**
 489 **levels. (A) Hatching time; (B) Hatching rate; (C) Heart rate.**

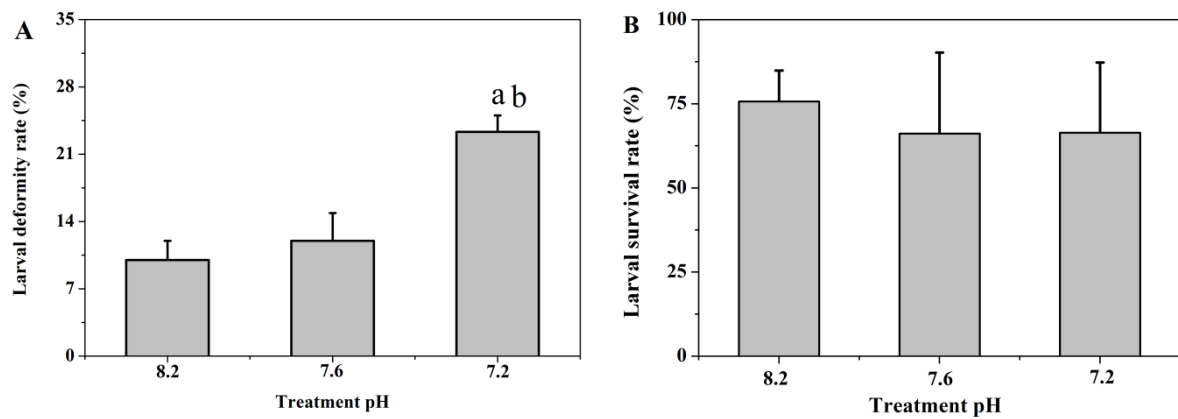

490

491 **Figure 4. The deformity and survival rates of larvae exposed to three pH levels. (A) Deformity rate; (B)**
 492 **Survival rate. The symbol a indicates that the value in pH 7.2 differs significantly from that in the control**
 493 **(pH 8.2), and symbol b indicates that the value in pH 7.2 differs significantly from that in pH 7.6.**

494

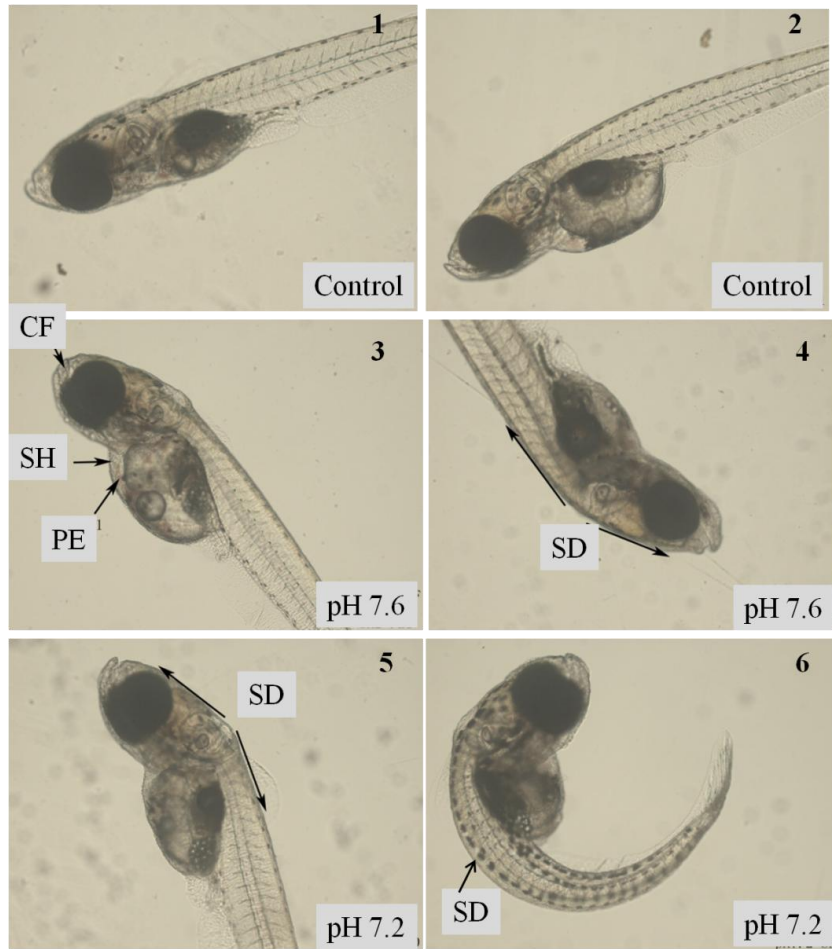

495
496
497
498

Figure 5. Morphological changes of medaka larvae exposed to three pH levels. 1~2: Control: Normal (pH 8.2); 3~4: pH 7.6 treatment; 5~6: pH 7.2 treatment. SD: Spinal deformities; CF: Craniofacial deformities; PE: Pericardial edema; SH: Stretched heart.

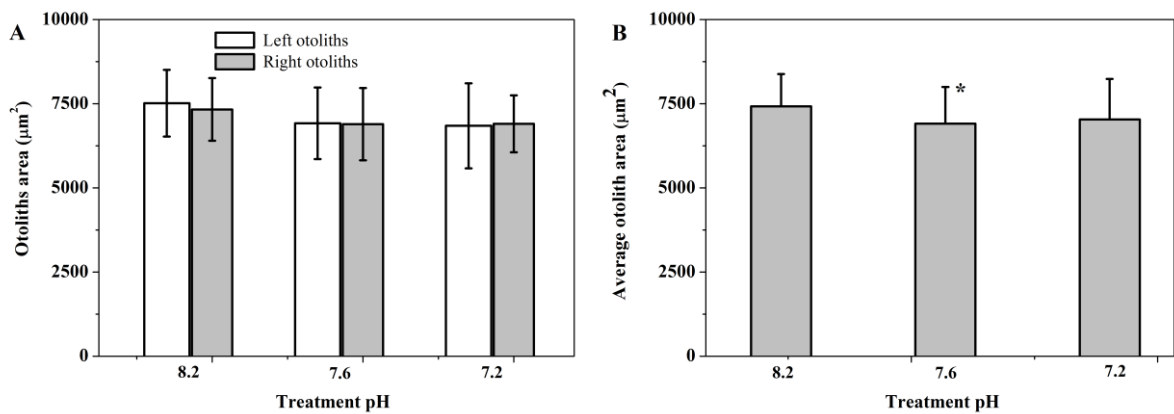

499
500
501
502

Figure 6. The effects of different pH levels on the otolith area of marine medaka larvae after 21 d of exposure. Asterisk indicates that the value in pH 7.6 treatment differed significantly from that in the control (pH 8.2).