

This discussion paper is/has been under review for the journal Biogeosciences (BG).  
Please refer to the corresponding final paper in BG if available.

# Carbon balance of surfaces vs. ecosystems: advantages of measuring eddy covariance and soil respiration simultaneously in dry grassland ecosystems

Z. Nagy<sup>1,2</sup>, K. Pintér<sup>1</sup>, M. Pavelka<sup>3</sup>, E. Darenová<sup>3</sup>, and J. Balogh<sup>1</sup>

<sup>1</sup>Plant Ecology Research Group of Hungarian Academy of Sciences, Szent István University, Páter u. 1., 2103 Gödöllő, Hungary

<sup>2</sup>Institute of Botany and Ecophysiology, Szent István University, Páter u. 1., 2103 Gödöllő, Hungary

<sup>3</sup>Institute of Systems Biology and Ecology, Czech Academy of Sciences Poříčí 3b, 60300 Brno, Czech Republic

Received: 26 January 2011 – Accepted: 28 January 2011 – Published: 4 February 2011

Correspondence to: Z. Nagy (nagy.zoltan@mkk.szie.hu)

Published by Copernicus Publications on behalf of the European Geosciences Union.

## Carbon balance of surfaces vs. ecosystems

Z. Nagy et al.

Title Page

Abstract

Introduction

Conclusions

References

Tables

Figures

◀

▶

◀

▶

Back

Close

Full Screen / Esc

Printer-friendly Version

Interactive Discussion



## Abstract

An automated open system for measurement of soil CO<sub>2</sub> efflux ( $R_{sc}$ ) was developed and calibrated against known fluxes and tested in the field, while measuring soil respiration also by the gradient method ( $R_{sg}$ ) at a dry sandy grassland (Bugac, Hungary). Ecosystem respiration ( $R_{eco}$ ) was measured by the eddy covariance technique. Small chamber size (5 cm in diameter) of the chamber system made it possible to use the chambers also in vegetation gaps, thereby avoiding the necessity of removing shoots, the disturbance of the spatial structure of vegetation and the upper soil layer. Low air flow rates associated with small chamber volume and chamber design allowed the overpressure range to stabilize between 0.05–0.12 Pa. While the correlation between ecosystem and soil CO<sub>2</sub> efflux rates as measured by the independent methods was significant,  $R_{eco}$  rates were similar or even lower than  $R_{sc}$  in the low flux (up to 2  $\mu\text{mol CO}_2 \text{ m}^{-2} \text{ s}^{-1}$ ) range, probably due to the larger than assumed storage flux. The gradient method showed both up and downward CO<sub>2</sub> fluxes originating from the main rooting zone after rains. Downward fluxes within the soil profile amounted to 15% of the simultaneous upward fluxes and to  $\sim 7.6\%$  of the total (upward) effluxes during the 3 months study. The upper 5 cm soil layer contributed to  $\sim 50\%$  of the total soil CO<sub>2</sub> efflux. The continuously operated automatic open chamber system and the gradient system makes possible the detection of situations when the eddy system underestimates  $R_{eco}$ , gives the lower limit of underestimation (chamber system) and helps in quantifying the downward flux component of soil respiration (gradient method) between the soil layers. These latter (downward) fluxes are expected to seriously affect (1) the  $R_{eco}$  vs. temperature response functions and (2) the net ecosystem exchange of CO<sub>2</sub> (NEE) vs. photon flux density response functions, therefore potentially affecting also the gap filling procedures and to led to a situation (3) when the measured surface and the real time ecosystem fluxes will necessarily differ in the short term. Simultaneous measurements of  $R_{eco}$  and soil CO<sub>2</sub> effluxes may reveal the time and degree of the above decoupling, thereby contributing to decrease uncertainty, associated with eddy

**BGD**

8, 941–973, 2011

## Carbon balance of surfaces vs. ecosystems

Z. Nagy et al.

Title Page

Abstract

Introduction

Conclusions

References

Tables

Figures

◀

▶

◀

▶

Back

Close

Full Screen / Esc

Printer-friendly Version

Interactive Discussion



flux measurements over flat terrains. While the correlation between chamber fluxes and gradient fluxes was strong, gradient fluxes were generally larger than the flux from chambers. Calibration of gradient flux system by chamber effluxes is proposed.

## 1 Introduction

5 The emission of CO<sub>2</sub> from the soil surface ( $R_s$ ) is the largest fraction (60–80%) of ecosystem respiration (Raich and Schlesinger, 1992; Janssens et al., 2002; Luo and Zhou, 2006). Available systems for  $R_s$  measurements use chambers of diameter of 10 cm or larger. This size often necessitates removal (cut) of aboveground biomass, especially in closed grasslands, where the average gap size between tussocks is smaller  
10 than this measure. Clearing off the above-ground biomass before the measurements (usually 24 h before the measurements, Bahn et al., 2008) is a serious intervention destroying the spatial structure of the vegetation including gap structure, also important in vegetation dynamics (Hook et al., 1994). Cutting affects radiation, temperature and moisture, pose stress to plants and lead to disruption of the photosynthate supply to  
15 roots and rhizospheric microbes (Tang et al., 2005a; Cao et al., 2004).

In spite of their simple design and easy operation, open system soil respiration systems are not widely used (Iritz et al., 1997; Fang and Moncrieff, 1996, 1998). The main problem of this configuration is the pressure difference between the chamber and the ambient air, often caused by the applied high flow rates. Pressure differences larger  
20 than a fifth of a Pa seriously affect the measured CO<sub>2</sub> efflux (Fang and Moncrieff, 1998; Smith et al., 2010). Serious changes in environmental conditions above the soil surface (decrease the boundary layer by high flow rates, low or too high CO<sub>2</sub> concentration) also should be avoided in chambers during the measurements (Subke et al., 2004).

Our aim was to develop a new, simple, cost effective open system suitable for soil  
25 CO<sub>2</sub> efflux measurements, and fulfilling the following criteria:

**BGD**

8, 941–973, 2011

## Carbon balance of surfaces vs. ecosystems

Z. Nagy et al.

Title Page

Abstract

Introduction

Conclusions

References

Tables

Figures

◀

▶

◀

▶

Back

Close

Full Screen / Esc

Printer-friendly Version

Interactive Discussion



## Carbon balance of surfaces vs. ecosystems

Z. Nagy et al.

Title Page

Abstract

Introduction

Conclusions

References

Tables

Figures

◀

▶

◀

▶

Back

Close

Full Screen / Esc

Printer-friendly Version

Interactive Discussion

- Minimising modification of environmental drivers of respiration as thought to be achieved by small diameter, small insertion depth and no collars (i.e. Wang et al., 2005).
- Avoiding disturbance of current photosynthetic supply to the root zone. Larger chamber diameter values would generally exclude to fulfill this criterion due to regular cutting/weeding in addition to the disturbance when setting up the system.
- The chamber should allow water to enter through the vent holes on the top (precipitation events) and from the perimeter toward the center of the chamber. Water transport is supposed to be adequate in the 2.5 cm distance (radius of the chamber) range.
- Automation: The system should serve as a tool for continuous checking of soil CO<sub>2</sub> efflux, and should be capable to operate for long periods when unattended.

Further goal of the study was to compare the soil CO<sub>2</sub> efflux rates as measured by the chamber method with  $R_{\text{eco}}$  from eddy-covariance measurements in an effort of addressing the problem of similar or higher  $R_s$  than  $R_{\text{eco}}$  values as reported already (Goulden et al., 1996; van Gorsel et al., 2007; Myklebust et al., 2008). In the present study we wished to contribute to decreasing the uncertainty arising from limitations typical during nighttime with eddy flux measurements over flat terrains (Massman and Lee, 2002; Smith et al., 2010). Investigations of soil respiration dynamics by the gradient method within the soil profile after rainstorms was another goal of the study, not lastly, because significant part of the total fluxes occur during these events in drought prone grasslands ecosystems (Xu et al., 2004). Information leading to better characterization of fluxes in these periods hopefully contributes to improved models of soil respiration and decreasing uncertainty of CO<sub>2</sub> balance estimates.

## 2 Materials and methods

### 2.1 Soil respiration measurements by the automated open system

The system consists of an infrared gas analyzer SBA-4 (PPSystems, UK, IRGA), two pumps (MP, P), mass flow meters (D6F-01A1-110, Omron Co. Kyoto, Japan, MFM1–4) and electric valves (V1–4) for each chamber and of four PVC-metal soil chambers (Fig. 1). Main pump of the system (Eheim 400, Eheim, Germany, MP) is situated in a 2 l buffer volume. Chambers are 10.4 cm high and with a diameter of 5 cm, covering about 19.6 cm<sup>2</sup> of the surface. The PVC chambers (C) are enclosed in a white metal cylinder with 2 mm airspace between to stabilize the chamber and to avoid warming by direct radiation. Four vent holes with a total area of 0.95 cm<sup>2</sup> were drilled on the top of the chambers. Vent holes also acted as to lead precipitation into the chambers.

Reference air flow from the main pump is divided two ways: one goes to the IRGA, the other one goes through MFMs into the chambers with a 220–240 ml min<sup>-1</sup> flow rate (each measured by MFMs). Inlet of reference air is at the lower part of the chambers, 1 cm above the soil surface. Air from the funnel in the chamber is sampled by a pump (P) with a 160–180 ml min<sup>-1</sup> flow rate and guided to the same IRGA. To measure the reference and the analysis cycle together took 14 s in this system considering also the necessary purge times. The system works as an open steady-state system (Fig. 1). No base collars in the soil were used with the chambers, sharpened chamber base is inserted into the soil to ~3–5 mm, thereby avoiding deeper disturbance of the soil (Wang et al., 2005).

The control of the system is provided by home made software written to operate a data logger CR23X (Campbell Sci., UK), performing timing of measurements on a particular chamber, switching of valves, measuring the signals from the MFMs, the IRGA and other sensors (see below) and also data storage. Air and soil temperature sensors, soil moisture sensor (thermocouples and CS616 water content reflectometer, Campbell Sci., UK) and a pressure sensor (SDP1000-L05, Sensirion AG, Staefa, Switzerland) for measuring pressure difference between the chamber and the ambient

**BGD**

8, 941–973, 2011

## Carbon balance of surfaces vs. ecosystems

Z. Nagy et al.

Title Page

Abstract

Introduction

Conclusions

References

Tables

Figures

◀

▶

◀

▶

Back

Close

Full Screen / Esc

Printer-friendly Version

Interactive Discussion



air are also attached to the data-logger. Low air flow rates, small chamber volume, chamber design (relatively large tube diameters, vent holes on the top of the chambers, inner funnel dimensions) allowed to stabilize the overpressure range between 0.05–0.12 Pa.

5 The system's parts (datalogger, IRGA, valves, air flow meters, pumps etc) were built into a waterproof box. The system was programmed using the Edlog software (Campbell Sci., UK) to measure a half hour in every two hours during the field measurements. Each chamber was measured for 3 min, by saving the average of the CO<sub>2</sub>-concentrations in the last minute. Average values of further variables (air flow rates, air  
10 and soil temperatures, soil water content, pressure differential between the chamber and the ambient air) were also saved at the same time.

Development, calibration and field test of the system was performed during 2007 and 2008 and the final version of the system from the summer, 2009 as described in the following sections.

## 15 2.2 Gradient method

Three GMP343 (Vaisala, Finland) IRGAs were inserted into the soil at 5, 12 and 35 cm depths, respectively, in the vicinity (within 3 m) of the eddy station and the soil respiration chambers (within 1–2 m distance range) at the Bugac site on chernozem type sandy soil (Pintér et al., 2008). The sensors were sampled by the CR5000 (Campbell,  
20 UK) datalogger (controlling eddy measurements, too) at 10 s and averaged half-hourly. Soil temperatures and soil (volumetric) water contents were measured and data stores with the same time resolution. A 0.6 m deep ditch was dug out, sensors inserted into one of the walls of the ditch at the depths noted above, finally the soil was packed back. Attention was paid to avoid disturbance of soil structure at places where the sensors  
25 have been inserted into and to pack back soil layers into the ditch in the same order as they were dug out.

The gradient method was applied using the diffusion model as in several works (e.g. Tang et al., 2003, 2005a; Moldrup et al., 1999; Myklebust et al., 2008), calculating the

**BGD**

8, 941–973, 2011

---

## **Carbon balance of surfaces vs. ecosystems**

Z. Nagy et al.

---

Title Page

Abstract

Introduction

Conclusions

References

Tables

Figures

◀

▶

◀

▶

Back

Close

Full Screen / Esc

Printer-friendly Version

Interactive Discussion





crosswind on sensible heat flux was corrected after Liu et al. (2001). Effect of density fluctuations on the turbulent fluxes was corrected by the method described in Webb et al. (1980). Damping effect of the sensor line averaging and the limited response time of the anemometer and the gas analyser were corrected by Moore (1986). Half-hourly CO<sub>2</sub> fluxes were modified by the storage term calculated from the rate of change in CO<sub>2</sub> concentration below the measuring level (Flanagan et al., 2002). Nighttime, storage corrected (Aubinet et al., 2001) values of  $R_{\text{eco}}$  measured at  $u^*$  higher than 0.1 m s<sup>-1</sup> were used for comparison to soil respiration values. Raw data were processed using an IDL program after Barcza et al. (2003).

## 2.4 Tests of the automated soil respiration measurement system

Performance of the new system was checked by (1) calibration of the system against CO<sub>2</sub> fluxes estimated independently and (2) testing the system in the field during continuous operation, unattended for weeks.

### 2.4.1 Calibration

Calibration of the new system was carried out on calibration tank, made after Pumpanen et al. (2004) in the Institute of Systems Biology and Ecology AS CR (ISBE). The calibration tank is of cylindrical shape with 1.13 m in diameter and 1.08 m in height. Internal volume of the tank is 1.08 m<sup>3</sup>, calibration area of the tank is 1.00 m<sup>2</sup>, which is realized as 0.12 m thick layer of pure quartz sand placed on perforated partition. Air pump sucks air sample from the tank to infrared gas analyzer (Li-820, Li-Cor, USA., equipped with the 5 cm length sample cell allowing to measure CO<sub>2</sub> concentration up to 20 000 ppm) and blows it back to the tank. The analyzer is connected to DL-3000 data logger (Delta-T Devices, UK). Concentration of CO<sub>2</sub> inside the tank was measured and logged every 15 min. Measured data were fitted by Chebyshev Rational Order 5/6 function (using software TableCurve 2-D, Systat, USA) CO<sub>2</sub> efflux from the tank was calculated as in Pumpanen et al. (2004).

**BGD**

8, 941–973, 2011

## Carbon balance of surfaces vs. ecosystems

Z. Nagy et al.

Title Page

Abstract

Introduction

Conclusions

References

Tables

Figures

◀

▶

◀

▶

Back

Close

Full Screen / Esc

Printer-friendly Version

Interactive Discussion





## 2.4.2 Field test

The system was set up after performing the calibration at Bugac, Hungary (Pintér et al., 2008) for 4 months to test it under different meteorological conditions and continuous operation. Two chambers were placed in vegetation gaps, and another two in a 5 trenched plot. Trenching was made in autumn of 2007, by removing all living roots from a 0.4 m × 0.6 m plot to 0.4 m depth, putting back the soil, and applying plexiglas sheets to 0.5 m depth at the sides to prevent root ingrowths. During the 4 months period the system was operational in spite of high temperatures (exceeding 38 °C) and rainstorms (Fig. 2), except for failures in electricity supply.

## 3 Results

### 3.1 Calibration of the chambers of the automated soil respiration system

The system was calibrated after checking for zero fluxes (i.e. by measuring a glass plate) against effluxes from a calibration tank. The agreement between the systems' fluxes is characterized by  $R^2$  values of linear fit between 0.934 and 0.969 (by 15 constraining the regression through the origin, Table 2., for fluxes within the range of 3.5–9  $\mu\text{mol CO}_2 \text{ m}^{-2} \text{ s}^{-1}$  (Fig. 3). Slopes were applied afterwards as calibration coefficients when calculating the fluxes during the field test.

### 3.2 Field test of the automated soil CO<sub>2</sub> efflux chamber system

Results from the continuous operation have shown that the two chambers placed in 20 vegetation gaps measured similar or higher values of soil respiration than  $R_{\text{eco}}$ , measured by the eddy covariance technique (Figs. 2 and 4) in the low flux ranges.  $R_{\text{sc}}$  from the trenched plot were generally lower than  $R_{\text{sc}}$  from the chambers placed between within natural vegetation gaps (between grass tufts), probably also due to lack of fresh carbon supply, even if the soil surface temperature might favored higher soil respiration

**BGD**

8, 941–973, 2011

## Carbon balance of surfaces vs. ecosystems

Z. Nagy et al.

Title Page

Abstract

Introduction

Conclusions

References

Tables

Figures

◀

▶

◀

▶

Back

Close

Full Screen / Esc

Printer-friendly Version

Interactive Discussion



rates, otherwise. This picture was different after rains, when chambers in the trenched plots measured similar or higher values than chambers in natural vegetation gaps.

The soil respiration measurement system was operational during the summer 2009, except for an electricity breakdown period during July, in spite of the large temperature range and precipitation events (Fig. 2). Precipitation pulses caused respiration bursts (Potts et al., 2006; Baldocchi et al., 2006), shown both by the eddy and the soil respiration systems. When pairing non-trenched  $R_{sc}$  data to nighttime eddy  $R_{eco}$  data (at higher than  $0.1 \text{ m s}^{-1} u^*$ ), the relation proved to be statistically significant in one hand, and  $R_{eco}$  in the low range (below  $2 \mu\text{mol CO}_2 \text{ m}^{-2} \text{ s}^{-1}$ ) was similar to or smaller than  $R_{sc}$ , on the other (Fig. 4). While the four chamber system (2 replications) might not provided enough data to characterize spatial variability,  $R_{sc}$  from the trenched plots may serve as a lower base for soil respiration estimations.

### 3.3 CO<sub>2</sub> concentration dynamics in the soil profile and soil respiration as measured by the gradient method

CO<sub>2</sub> concentration in the measured soil layers showed dependence on soil layer's wetness, with superimposed daily cycles (probably reflecting that of temperature) and occasional high CO<sub>2</sub> concentrations after rain events (Fig. 5). After rainstorm events, the usual CO<sub>2</sub> cc gradients were reversed for several hours (Fig. 6). CO<sub>2</sub> concentrations in the upper 5 cm layer peaked 3 to 7 h, while 6 to 9 h in 12 cm depth and 9 to 17 h in 30cm depth after the end of the rain event and also several hours after SWC already leveled off (Fig. 6). Increase of CO<sub>2</sub> concentration at a particular depth depended on precipitation sum brought by a rain event (Fig. 7) during the drought.

Soil respiration as measured by the gradient method ( $R_{sg}$ ) strongly decreased with soil depth (Fig. 8). After precipitation events, during the dry summer  $R_{sg}$  within the soil profile had both up and downward components as calculated from the 5 and 12.5 cm sensor depths, respectively (Fig. 8). The downward CO<sub>2</sub> fluxes were caused by temporal reversal of CO<sub>2</sub> concentration gradients as developed after rains (Figs. 6, 8, 9). The longest continuous period of downward flux was 4.5 days, duration of downward fluxes

**BGD**

8, 941–973, 2011

## Carbon balance of surfaces vs. ecosystems

Z. Nagy et al.

Title Page

Abstract

Introduction

Conclusions

References

Tables

Figures

◀

▶

◀

▶

Back

Close

Full Screen / Esc

Printer-friendly Version

Interactive Discussion



(i.e. when both up and downward fluxes occurred) was 11.4% of the time. Magnitude of downward fluxes was 15% of upward fluxes occurring at the same time and ~ 7.6% of the total upward flux within the 3 months period. The upper 5 cm soil layer contributed to ~ 50% of the total  $R_{sg}$  flux during the four month study period, shown in Fig. 8.

### 5 3.4 Comparison of soil respiration values as measured by the gradient method ( $R_{sg}$ ) and by the open system's chambers ( $R_{sc}$ )

$R_{sg}$  data from periods of the  $CO_2$  concentration gradient inversions after rain events (as shown in Fig. 6) were excluded from the comparison to parallel chamber efflux data. The regression between  $R_{sg}$  and  $R_{sc}$  was highly significant (Fig. 10).  $R_{sg}$  values were higher than the  $R_{sc}$  (considering the two chambers' data from the untilled treatment). While spatial heterogeneity of soil  $CO_2$  efflux might well have caused the difference between the two chambers, overestimation of soil respiration by the gradient method is suggested as  $R_{sc}$  values were calibrated against an independent flux measurement (i.e. the efflux from the calibration tank). Equation (2) assumes steady state conditions, that are unlikely to persist during rapid SWC changes. Gradient fluxes increased much more after rain events than chamber fluxes. Consequently, the calculated conductance and tortuosity values are probably in error during these periods.

## 4 Discussion

### 4.1 Characteristics of the soil respiration system

20 The chamber system for soil respiration measurement was successfully calibrated against known  $CO_2$  effluxes in the lab. Performance of the system in the field was reliable (not considering cases of energy supply failures). Main advantages of the new system are the small size of chambers, allowing measurements to be done within (natural) vegetation gaps/between grass tufts, with minimizing the disturbance of the soil

**BGD**

8, 941–973, 2011

## Carbon balance of surfaces vs. ecosystems

Z. Nagy et al.

Title Page

Abstract

Introduction

Conclusions

References

Tables

Figures

◀

▶

◀

▶

Back

Close

Full Screen / Esc

Printer-friendly Version

Interactive Discussion



---

**Carbon balance of  
surfaces vs.  
ecosystems**Z. Nagy et al.

---

Title Page

Abstract

Introduction

Conclusions

References

Tables

Figures

◀

▶

◀

▶

Back

Close

Full Screen / Esc

Printer-friendly Version

Interactive Discussion



structure and the spatial structure of the vegetation. Further advantages are the possibility for long term, unattended measurement of soil CO<sub>2</sub> efflux (reliable operation through long time periods) and environmental variables, mobility and easy installation, lower probability of technical failures due to the simple system design (no opening and closing, so no moving parts). Avoiding disturbance of spatial structure is thought to be important because this structure might have been formed through years and patches with different vegetation cover are expected to behave differently, considering the dependence of soil respiration on current photosynthesis (Högberg et al., 2001; Tang et al., 2005b), for example. When applying larger chambers, the disturbance of the spatial structure (i.e. partial or complete removal of vegetation in order to have enough space to insert the chamber) is expected to disturb also the relative weights of processes contributing to soil respiration (i.e. root respiration, microbial respiration). A disadvantage of the system operated in the same place for extended periods is the potential possibility to cause the temperature and water content of the soil to differ from that of the bulk soil. On the other hand, the chambers are insulated against radiation (outer white cylinder), they are ventilated during measurements, there are vent holes on the top of the chambers (also serving to allow precipitation water to enter into the chamber) and the radius of the chamber is 2.5 cm. Any gradient of the driving variables (i.e. soil temperature and water content) developing from inside, will be balanced from outside and from below at that scale (2.5 cm). The commonly applied soil water content sensors are larger than this scale, therefore no data are available to characterize the chamber effect at this scale. Tiny thermocouples may perhaps be applied for detecting temperature gradients. One further disadvantage of the system in its present setup is that it does not manage the problem of spatial variability of soil respiration. The size of the eddy flux footprint is larger by several orders of magnitude, than the area covered by the soil respiration chamber. Considering larger chambers (diameter of 10 cm, for example) would probably not improve much on this problem. Applying more chambers and geo-statistical analysis of the data may help on the scale problem by providing the average patch diameter (as to be inferred from semivariogram analysis) for soil respiration. The

range associated with semivariance maximum of  $R_s$  data for the Bugac grassland was found to be between 0.8 m to 4 m depending on season and the water availability (Fóti et al., 2008), suggesting that average soil respiration of a patch/area of this diameter can be considered as spatially representative for this grassland.

Using  $R_{sc}$  data from the trenched plot as lower base value for soil respiration was used in this study.  $R_{sc}$  average from trenched plots was generally lower (except immediately after rains) than  $R_{sc}$  from the chambers placed between the tussocks, supporting this approach. On the other hand, estimating the upper limit of the  $R_s$  range is not possible on the base of the present data.

## 4.2 Comparison of different methods for measuring soil CO<sub>2</sub> efflux

Nighttime  $R_{eco}$  as measured by the eddy system was in many cases smaller than soil respiration measured by the automated chamber system ( $R_{sc}$ ). While this is not acceptable, in one hand, there are several possible explanations on the other and the same situation has also been observed in other studies (Goulden et al., 1996; van Gorsel et al., 2007; Myklebust et al., 2008). Spatial heterogeneity of fluxes, and unaccounted storage are among the candidates, the latter showing up in build up of CO<sub>2</sub> below the level of measurement (Fig. 11) during still nights, a situation that can be common in the plains over smooth and flat surfaces (Smith et al., 2010). While measurements over flat terrain may be less prone to advection (Osborne et al., 2010), low atmospheric turbulence conditions can become more significant in affecting storage (Haszpra et al., 2005; Smith et al., 2010). The above limitation of the eddy technique at localities where low turbulence conditions are frequent may necessitate application of measurements, independent of the eddy system for measuring soil CO<sub>2</sub> effluxes. Possible tool to approach the problem of low nighttime  $R_{eco}$  fluxes is that of multiple constraints, when independent measurements are considered in parallel (Myklebust et al., 2008). To date, chamber measurements are the most direct way of determining  $R_s$ , although conductance within the chamber is undoubtedly different from the one that would be without the chamber (Balogh et al., 2007).

**BGD**

8, 941–973, 2011

## Carbon balance of surfaces vs. ecosystems

Z. Nagy et al.

Title Page

Abstract

Introduction

Conclusions

References

Tables

Figures

◀

▶

◀

▶

Back

Close

Full Screen / Esc

Printer-friendly Version

Interactive Discussion



The gradient method gave higher fluxes of soil respiration than the ones measured by the open system ( $R_{sg} > R_{sc}$ ). The regression between the two, physically independent systems was highly significant, except around rain events. These events may differentially affect the tortuosity and connectedness of the soil diffusion paths at different depths (e.g. advance of the wetting front), thereby causing uncertainty in conductance estimations. Overestimation of soil  $\text{CO}_2$  efflux at the soil surface by the gradient method is suggested, because  $R_{sc}$  values (compared to parallel  $R_{sg}$  data) were calibrated against an independent flux measurement (i.e. the efflux from the calibration tank). Possible explanation for the deviation between the two methods is the error in the calculated conductance values. This error, in turn, might most probably have arisen from the tortuosity factor estimates based on the silt and clay fractions (Tang et al., 2005a). The strong correlation between  $R_{sc}$  and  $R_{sg}$  values suggests that after a longer period of continuous parallel operation  $R_{sc}$  value could be used to scale  $R_{sg}$  by adjusting the tortuosity value (parameter  $S$  in Eq. 2), for example.

### 4.3 Implications for partitioning fluxes

Inversion of the usual (downward increasing)  $\text{CO}_2$  concentration gradient within the soil profile resulted in  $\text{CO}_2$ -fluxes of downward direction. Magnitude of downward fluxes are interesting because the  $\text{CO}_2$  carried by these fluxes will start to efflux from the soil possibly several hours (or even days) later. Fluxes within the soil profile of downward direction occurring after rains (interrupting serious droughts) amounted to 15% of the simultaneous upward fluxes and to  $\sim 7.6\%$  of the total (upward) effluxes during the 3 months study. The longest (continuous) duration downward flux lasted for 4 and half days, with an average intensity of  $\sim 1 \mu\text{mol CO}_2 \text{ m}^{-2} \text{ s}^{-1}$ , when the upward  $R_s$  flux was in the range of 4 to  $6 \mu\text{mol CO}_2 \text{ m}^{-2} \text{ s}^{-1}$  (Fig. 8). This component and the wind shear dependent storage flux component (Hirsch et al., 2004) together may seriously affect  $R_{\text{eco}}$  estimates (Flechard et al., 2005; van Gorsel et al., 2007; Myklebust et al., 2008), with effect on the apparent temperature dependence of  $R_{\text{eco}}$ . Part of soil respiration derived  $\text{CO}_2$  was available for eddy (or chamber) detection only with significant delay

## Carbon balance of surfaces vs. ecosystems

Z. Nagy et al.

Title Page

Abstract

Introduction

Conclusions

References

Tables

Figures

◀

▶

◀

▶

Back

Close

Full Screen / Esc

Printer-friendly Version

Interactive Discussion



after the respiration process took place in the soil layers. This situation led to temporal decoupling of above and belowground respiration processes. The decoupling of  $R_{\text{eco}}$  components is not important when considering that the  $\text{CO}_2$  transported downward, will finally efflux from the soil and the carbon balance of the surface will be valid in the longer term. The decoupling of  $R_{\text{eco}}$  components (surface vs ecosystem fluxes) may become important however, when considering partitioning and gap filling procedures, usually working at half hourly time steps. The phenomena (and determination of the possible relative magnitude) of downward respiratory fluxes is probably of general importance in seriously water limited ecosystems.

## 5 Conclusions

The open system developed for measurement of soil respiration was successfully calibrated against effluxes from a calibration tank. The new system measured soil  $\text{CO}_2$  effluxes for months without malfunction.

Notable findings from the present study are, that (1) independent measurements of  $R_s$  by the open system chamber and the gradient technique were significantly correlated to each other (2) the eddy technique underestimated  $R_{\text{eco}}$  in the low flux range as shown by independent chamber measurement of soil respiration. This underestimation was probably related to the calculation of storage under the eddy measurement level without  $\text{CO}_2$  concentration profile in the (air) control volume, therefore application of profile measurements is proposed (3) the uncertainty caused by occurrence of eddy flux measurement limitations can be reduced by application of the chamber technique and setting the lower limit of  $R_{\text{eco}}$  (4) downward fluxes of respiratory origin in droughted grasslands may be common after rainstorms. The consequence is the difference between surface and real time ecosystem fluxes leading to increased uncertainties in the calculated C-balances at hourly and daily scales and also when applying gap-filling functions and/or procedures. The problem basically is the temporal lag between production and efflux of  $\text{CO}_2$  from the soil. As with the balance, increasing the averaging

**BGD**

8, 941–973, 2011

## Carbon balance of surfaces vs. ecosystems

Z. Nagy et al.

Title Page

Abstract

Introduction

Conclusions

References

Tables

Figures

◀

▶

◀

▶

Back

Close

Full Screen / Esc

Printer-friendly Version

Interactive Discussion



## Carbon balance of surfaces vs. ecosystems

Z. Nagy et al.

Title Page

Abstract

Introduction

Conclusions

References

Tables

Figures

◀

▶

◀

▶

Back

Close

Full Screen / Esc

Printer-friendly Version

Interactive Discussion



time might be considered as an option. On the other hand, the lag is generally not considered when fitting  $R_{\text{eco}}$  against  $T_s$  in subsequent use for gap filling purposes. While neglecting this time lag may be acceptable when calculating surface fluxes in general, it is probably not so in cases when downward fluxes of varying duration and intensity occur within the soil profile. Probability of these events is high after rains in an otherwise dry period. These situations are responsible for significant  $\text{CO}_2$ -fluxes in dry ecosystems (Xu et al., 2004), showing the necessity to better describe the component processes. The 15% share of downward fluxes within the soil profile as experienced during and immediately after rain events in this study seems to be large enough to seriously affect gap filling procedures. The strong correlation between data, measured by independent systems shows the possible utilization of these to use the multiple constraints approach.

*Acknowledgements.* The financial support of the Hungarian Research Fund (OTKA-K75638), NitroEurope IP (017810-2) and Hungarian-Czech Science and Technology (TÉT-CZ 2/2006), OC08021 from ME of CR and AVOZ 60870520 from AS CR projects are gratefully acknowledged.

## References

- Aubinet, M., Chermanne, B., Vandenhaute, M., Longdoz, B., Yernaux, M., and Laitat, E.: Long term carbon dioxide exchange above a mixed forest in the Belgian Ardennes, *Agric. Forest Meteorol.*, 108, 4, 293–315, 2001.
- Bahn, M., Rodeghiero, M., Anderson-Dunn, M., Dore, S., Gimeno, C., Drösler, M., Williams, M., Ammann, C., Berninger, F., Flechard, C., Jones, S., Balzarolo, M., Kumar, S., Newesely, C., Priwitzer, T., Raschi, A., Siegwolf, R., Susiluoto, S., Tenhunen, J., Wohlfahrt, G., and Cernusca, A.: Soil Respiration in European Grasslands in Relation to Climate and Assimilate Supply, *Ecosystems*, 11, 1352–1367, 2008.
- Baldocchi, D., Tang, J., and Xu L.: How switches and lags in biophysical regulators affect spatial-temporal variation of soil respiration in an oak-grass savanna, *J. Geophys. Res.*, 111, G02008, doi:10.1029/2005JG000063, 2006.



## Carbon balance of surfaces vs. ecosystems

Z. Nagy et al.

Title Page

Abstract

Introduction

Conclusions

References

Tables

Figures

◀

▶

◀

▶

Back

Close

Full Screen / Esc

Printer-friendly Version

Interactive Discussion



- Balogh, J., Nagy, Z., Fóti, Sz., Pintér, K., Czóbel, Sz., Péli, E. R., Acosta, M., Marek, M. V., Csintalan, Zs., and Tuba, Z.: Comparison of CO<sub>2</sub> and H<sub>2</sub>O fluxes over grassland vegetations measured by the eddy-covariance technique and by open system chamber, *Photosynthetica*, 45, 2, 288–292, 2007.
- 5 Barcza, Z., Haszpra, L., Kondo, H., Saigusa, N., Yamamoto, S., and Bartholy, J.: Carbon exchange of grass in Hungary, *Tellus B*, 55, 187–196, 2003.
- Cao, G., Tang, Y., Mo, W., Wang, Y., Li, Y., and Zhao, X.: Grazing intensity alters soil respiration in an alpine meadow on the Tibetan Plateau, *Soil Biol. Biochem.*, 36, 237–243, 2004.
- Fang, C. and Moncrieff, J. B.: An improved dynamic chamber technique for measuring CO<sub>2</sub> efflux from the surface of soil, *Funct. Ecol.*, 10, 297–305, 1996.
- 10 Fang, C. and Moncrieff, J. B.: An open-top chamber for measuring soil respiration and the influence of pressure difference on CO<sub>2</sub> efflux measurement, *Funct. Ecol.*, 12, 319–325, 1998.
- Flanagan, L. B., Wever, L. A., and Carlson, P. J.: Seasonal and interannual variation in carbon dioxide exchange and carbon balance in a northern temperate grassland, *Glob. Change Biol.*, 8, 599–615, 2002.
- 15 Flechard, C. R., Neftel, A., Jocher, M., Ammann, C., Leifeld, J., and Fuhrer, J.: Temporal changes in soil pore space CO<sub>2</sub> concentration and storage under permanent grassland, *Agric. Forest Meteorol.*, 142, 66–84, 2007.
- 20 Fóti, Sz., Balogh, J., Nagy, Z., Bartha, S., Ürmös, Zs., and Tuba, Z.: Temporal and spatial variability and pattern of soil respiration in loess grassland, *Community Ecol.*, 9, 57–64, 2008.
- van Gorsel, E., Leuning, R., Cleugh, H. A., Keith, H., and Suni, T.: Nocturnal carbon efflux: reconciliation of eddy covariance and chamber measurements using an alternative to the  $u^*$ -threshold filtering technique, *Tellus B*, 59, 397–403, 2007.
- 25 Goulden, M. L., Munger, J. W., Fan, S. M., Daube, B. C., and Wofsy, S. C.: Measurements of carbon sequestration by long-term eddy covariance: Methods and a critical evaluation of accuracy, *Glob. Change Biol.*, 2, 169–182, 1996.
- Haszpra, L., Barcza, Z., Davis, K. J., and Tarczay, K.: Long-term tall tower carbon dioxide flux monitoring over an area of mixed vegetation, *Agric. Forest Meteorol.*, 132, 58–77, 2005.
- 30 Hirsch, A. I., Trumbore, S. E., and Goulden, M. L.: The surface CO<sub>2</sub> gradient and pore-space storage flux in a high-porosity litter layer, *Tellus B*, 56, 312–321, 2004.
- Högberg, P., Nordgren, A., Buchmann, N., Taylor, A. F. S., Ekblad, A., Högberg, M. N., Nyberg,

## Carbon balance of surfaces vs. ecosystems

Z. Nagy et al.

Title Page

Abstract

Introduction

Conclusions

References

Tables

Figures

◀

▶

◀

▶

Back

Close

Full Screen / Esc

Printer-friendly Version

Interactive Discussion



- G., Ottosson-Löfvenius, M., and Read, D. J.: Large-scale forest girdling shows that current photosynthesis drives soil respiration, *Nature*, 411, 789–792, 2001.
- Hook, P. B., Lauenroth, W. K., and Burke, I. C.: Spatial patterns of roots in a semiarid grassland: abundance of canopy openings and regeneration gaps, *J. Ecol.*, 82, 485–494, 1994.
- 5 Iritz, Z., Lindroth, A., and Gärdenäs, A.: Open ventilated chamber system for measurements of H<sub>2</sub>O and CO<sub>2</sub> fluxes from the soil surface, *Soil Technol.*, 10, 169–184, 1997.
- Janssens, A., Lankreijer, H., Matteucci, G., Kowalski, A. S., Buchmann, N., Epron, D., Pilegaard, K., Kutsch, W., Longdoz, B., Grünwald, T., Montagnani, L., Dore, S., Rebmann, C., Moors, E. J., Grelle, A., Rannik, Ü., Morgenstern, K., Oltchev, S., Clement, R.,  
 10 Guðmundsson, J., Minerbi, S., Berbigier, P., Ibrom, A., Moncrieff, J., Aubinet, M., Bernhofer, C., Jensen, N. O., Vesala, T., Granier, A., Schulze, E. -D., Lindroth, A., Dolman, A. J., Jarvis, P. G., Ceulemans, R. and Valentini, R.: Productivity overshadows temperature in determining soil and ecosystem respiration across European forests, *Glob. Change Biol.*, 7, 269–278, 2002.
- 15 Jones, H. G.: *Plants and Microclimate: A Quantitative Approach to Environmental Plant Physiology*, Cambridge University Press, New York, 1992.
- Liang, N. S., Nakadai, T., Hirano, T., Qu, L. Y., Koike, T., Fujinuma, Y., and Inoue, G.: In situ comparison of four approaches to estimating soil CO<sub>2</sub> efflux in a northern larch (*Larix kaempferi* Sarg.) forest, *Agric. Forest Meteorol.*, 123, 97–117, 2004.
- 20 Liu, H. P., Peters, G., and Foken, T.: New equations for sonic temperature variance and buoyancy heat flux with an omnidirectional sonic anemometer, *Bound-Lay. Meteorol.*, 100, 459–468, 2001.
- Luo, Y. and Zhou, X.: *Soil respiration and the environment*. Burlington, MA and San Diego, CA, USA, Academic Press, 2006.
- 25 Massman, W. J. and Lee, X.: Eddy covariance flux corrections and uncertainties in long-term studies of carbon and energy exchanges, *Agric. Forest Meteorol.*, 113, 121–144, 2002.
- Moldrup, P., Olesen T., Yamaguchi, T., Schjønning, P., and Rolston, D. E.: Modeling diffusion and reaction in soils: VIII. Gas diffusion predicted from single-potential diffusivity or permeability measurements, *Soil Sci.*, 164, 75–81, 1999.
- 30 van der Molen, M. K., Gash, J. H. C., and Elbers, J. A.: Sonic anemometer (co)sine response and flux measurement – II. The effect of introducing an angle of attack dependent calibration, *Agric. Forest Meteorol.*, 122, 95–109, 2004.
- Moore, C. J.: Frequency-response corrections for eddy-correlation systems, *Bound-Lay. Mete-*

## Carbon balance of surfaces vs. ecosystems

Z. Nagy et al.

Title Page

Abstract

Introduction

Conclusions

References

Tables

Figures

◀

▶

◀

▶

Back

Close

Full Screen / Esc

Printer-friendly Version

Interactive Discussion



orol., 37, 17–35, 1986.

Myklebust, M. C., Hipps, L. E., and Ryel, R. J.: Comparison of eddy covariance, chamber, and gradient methods of measuring soil CO<sub>2</sub> efflux in an annual semi-arid grass, *Bromus tectorum*, *Agric. Forest Meteorol.*, 148, 1894–1907, 2008.

5 Pintér, K., Nagy, Z., Barcza, Z., Balogh, J., Czóbel, Sz., Csintalan, Zs., and Tuba, Z.: Inter-annual variability of grasslands' carbon balance depends on soil type, *Community Ecol.*, 9, 43–48, 2008.

Osborne, B., Saunders, M., Walmsley, D., Jones, M., and Smith, P.: Key questions and uncertainties associated with the assessment of the cropland greenhouse gas balance, *Agr. Ecosyst. Environ.*, 139, 3, 293–301, 2010.

10 Potts, D. L., Huxma, T. E., Enquis, B. J., Weltzin, J. F., and Williams, D. G.: Resilience and resistance of ecosystem functional response to a precipitation pulse in a semi-arid grassland, *J. Ecol.*, 94, 23–30, 2006.

Pumpanen, J., Kolari, P., Ilvesniemi, H., Minkkinen, K., Vesala, T., Niinistö, S., Lohila, A., Larmola, T., Morero, M., Pihlatie, M., Janssens, I., Yuste, J. C., Günzweig, J. M., Reth, Subke, J. A., Savage, K., Kutsch, W., Østreg, G., Ziegler, W., Anthony, P., Lindroth, A., and Hari, S. P.: Comparison of different chamber techniques for measuring soil CO<sub>2</sub> efflux, *Agric. Forest Meteorol.*, 123, 159–176, 2004.

15 Raich, J. W. and Schlesinger, W. H.: The global carbon dioxide flux in soil respiration and its relationship to vegetation and climate, *Tellus B*, 44(2), 81–99, 1992.

Smith, P., Lanigan, G., Kutsch, W. L., Buchmann, N., Eugster, W., Aubinet, M., Ceschia, E., Béziat, P., Yeluripati, J. B., Osborne, B., Moors, E. J., Brut, A., Wattenbach, M., Saunders, M., and Jones, M.: Measurements necessary for assessing the net ecosystem carbon budget of croplands, *Agr. Ecosyst. Environ.*, 139, 3, 302–315, 2010.

25 Subke, J.-A., Inglima, I., Peressotti, A., Vedove, G. D., and Cotrufo, M. F.: A new technique to measure soil CO<sub>2</sub> efflux at constant CO<sub>2</sub> concentration, *Soil Biol. Biochem.*, 36, 1013–1015, 2004.

Tang, J., Baldocchi, D., Qi, Y., and Xu, L.: Assessing soil CO<sub>2</sub> efflux using continuous measurements of CO<sub>2</sub> profiles in soils with small solid state sensors, *Agric. Forest Meteorol.*, 118, 207–220, 2003.

30 Tang, J., Misson, L., Gerhenson, A., Cheng, W., and Goldstein, A. H.: Continuous measurements of soil respiration with and without roots in a ponderosa pine plantation in the Sierra Nevada Mountains, *Agric. Forest Meteorol.*, 132, 212–227, 2005a.

---

**Carbon balance of  
surfaces vs.  
ecosystems**

Z. Nagy et al.

[Title Page](#)[Abstract](#)[Introduction](#)[Conclusions](#)[References](#)[Tables](#)[Figures](#)[◀](#)[▶](#)[◀](#)[▶](#)[Back](#)[Close](#)[Full Screen / Esc](#)[Printer-friendly Version](#)[Interactive Discussion](#)

- Tang, J. W., Baldocchi, D. D., and Xu, L.: Tree photosynthesis modulates soil respiration on a diurnal time scale, *Glob. Change Biol.*, 11, 1298–1304, 2005b.
- Vickers, D. and Mahrt, L.: Quality control and flux sampling problems for tower and aircraft data, *J. Atmos. Ocean. Tech.*, 14, 512–526, 1997.
- 5 Wang, W. J., Zu, Y. G., Wang, H. M., Hirano, T., Takagi, K., Sasa, K., and Koike, T.: Effect of collar insertion on soil respiration in a larch forest measured with a LI-6400 soil CO<sub>2</sub> flux system, *J. Forest Res.-Jpn.*, 10, 57–60, 2005.
- Webb, E. K., Pearman, G. I., and Leuning, R.: Correction of flux measurements for density effects due to heat and water-vapor transfer, *Q. J. Roy. Meteor. Soc.*, 106, 85–100, 1980.
- 10 Wilczak, J. M., Oncley, S. P., and Stage, S. A.: Sonic anemometer tilt correction algorithms, *Bound-Lay. Meteorol.*, 99, 127–150, 2001.
- Xu, L. K., Baldocchi, D. D., and Tang, J. W.: How soil moisture, rain pulses, and growth alter the response of ecosystem respiration to temperature, *Global Biogeochem. Cy.*, 18, 4, GB4002, doi:10.1029/2004GB002281, 2004.

## Carbon balance of surfaces vs. ecosystems

Z. Nagy et al.

Title Page

Abstract

Introduction

Conclusions

References

Tables

Figures

◀

▶

◀

▶

Back

Close

Full Screen / Esc

Printer-friendly Version

Interactive Discussion



**Table 1.** Depths of sampled soil layers for computations of bulk densities, air filled porosity, the tortuosity factor as used in Eqs. (1) and (2) and the average soil organic matter content (in  $\text{g C kg}^{-1}$  dry soil) at the different depths.

Layers measured	reference depths (cm)	$\rho_b$ ( $\text{g cm}^{-3}$ )	$\eta$	$S$	$C_{\text{org}}$ ( $\text{g kg}^{-1}$ )
Upper	0–5	1.18	0.554	0.87	51.5
Mid	10–20	1.35	0.491	0.91	20.3
Lower	30–50	1.44	0.457	0.94	3.8

## Carbon balance of surfaces vs. ecosystems

Z. Nagy et al.

**Table 2.** Slopes and determination coefficients ( $R^2$ ) of linear regressions constrained through the origin (model  $y = mx$ ) between the “true” CO<sub>2</sub> effluxes (the efflux as calculated for the calibration tank) and the efflux rates as measured by the chambers of the new system (ch1–4). The slopes were used later on (during evaluation of field measurements) as calibration coefficients.

	ch1	ch2	ch3	ch4
slope	1.05	0.99	0.95	0.93
$R^2$	0.967	0.969	0.955	0.934

Title Page

Abstract

Introduction

Conclusions

References

Tables

Figures

◀

▶

◀

▶

Back

Close

Full Screen / Esc

Printer-friendly Version

Interactive Discussion



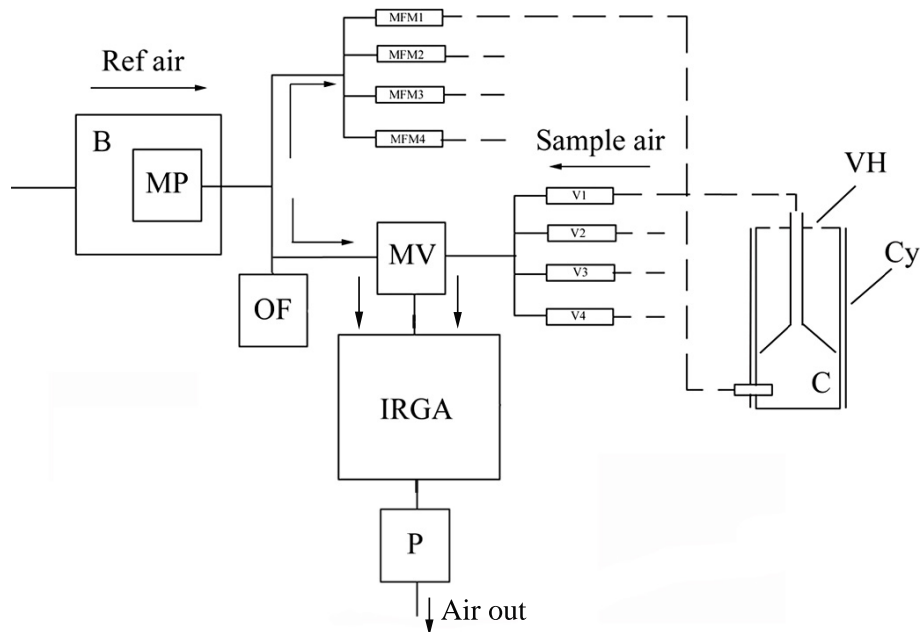

**Fig. 1.** Schematic air-flow diagram of the system (B: buffer volume, MP: main pump, P: sampling pump, OF: overflow, MFM1–4: mass flowmeters, MV: main valve, V1–4: valves, VH: vent holes, C: chamber with a funnel, Cy: metal cylinder, IRGA: gas analyzer, Ref air: reference air flow, Sample air: sample air flow, Air out: air outlet from the system)

**Carbon balance of surfaces vs. ecosystems**

Z. Nagy et al.

Title Page

Abstract Introduction

Conclusions References

Tables Figures

◀ ▶

◀ ▶

Back Close

Full Screen / Esc

Printer-friendly Version

Interactive Discussion



## Carbon balance of surfaces vs. ecosystems

Z. Nagy et al.

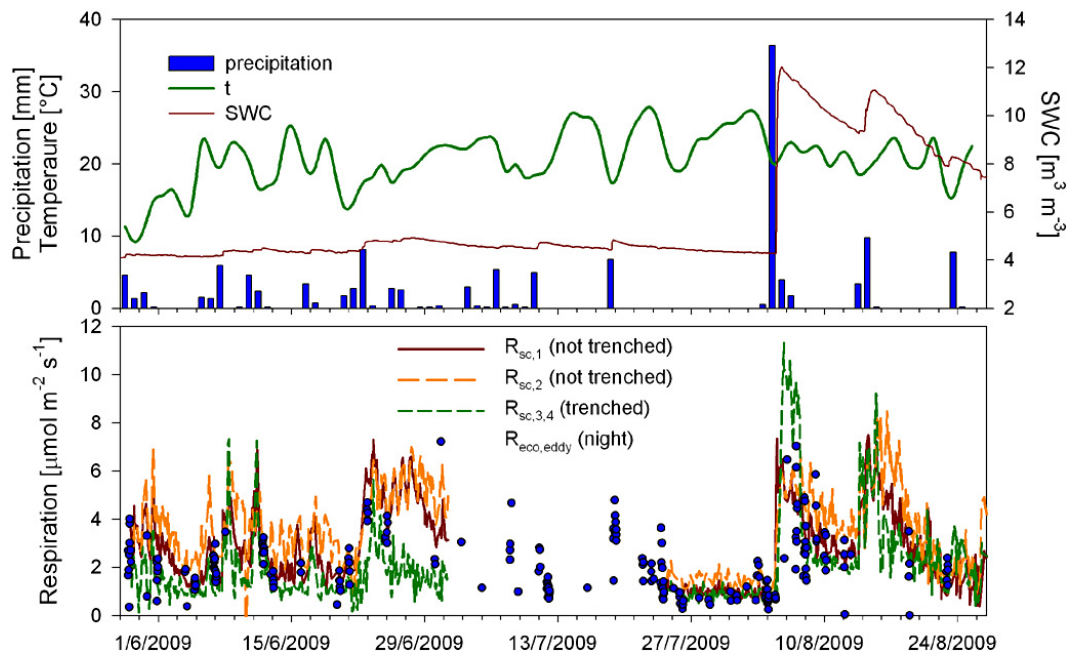

**Fig. 2.** Time courses of  $R_{eco}$  (nighttime, storage corrected,  $u^*$  filtered (threshold:  $0.1 \text{ m s}^{-1}$ ) EC data,  $R_{sc}$  from chambers placed in vegetation gaps (not trenched) and from the trenched plots (lower panel) and precipitation (upper panel left axis), daily average temperature (left axis) and volumetric soil water content (right axis) in the upper 30 cm of the soil during summer, 2009 at Bugac site. Lack of  $R_{sc}$  data (mid of the graph) was caused by disrupts in electricity supply.

Title Page

Abstract

Introduction

Conclusions

References

Tables

Figures

◀

▶

◀

▶

Back

Close

Full Screen / Esc

Printer-friendly Version

Interactive Discussion





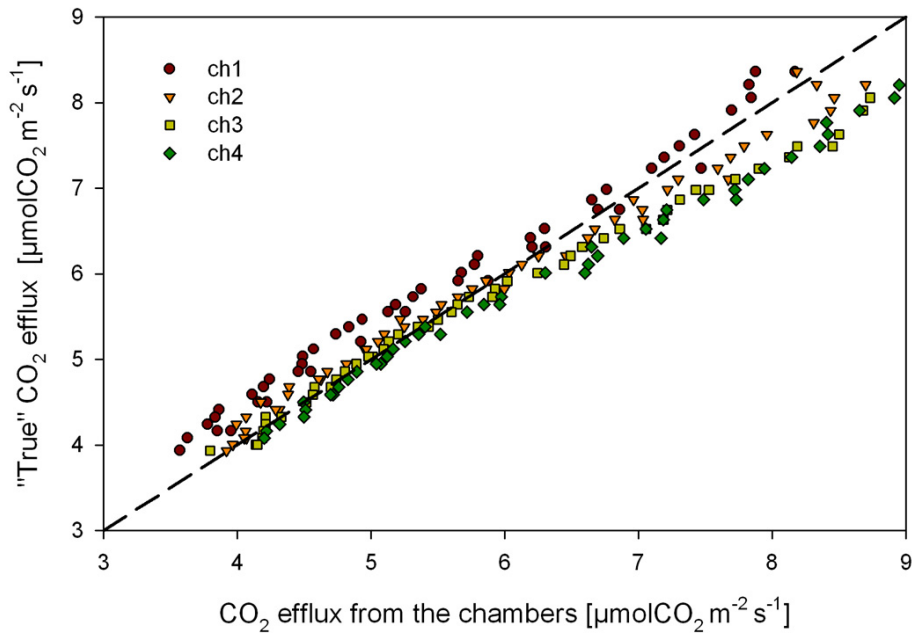

**Fig. 3.** CO<sub>2</sub> fluxes from the calibration tank ("true" CO<sub>2</sub> efflux) vs. the fluxes as measured by the four chambers (ch1–4) of the soil respiration system. The 1:1 line is shown (dashed line).

**Carbon balance of surfaces vs. ecosystems**

Z. Nagy et al.

Title Page

Abstract Introduction

Conclusions References

Tables Figures

◀ ▶

◀ ▶

Back Close

Full Screen / Esc

Printer-friendly Version

Interactive Discussion



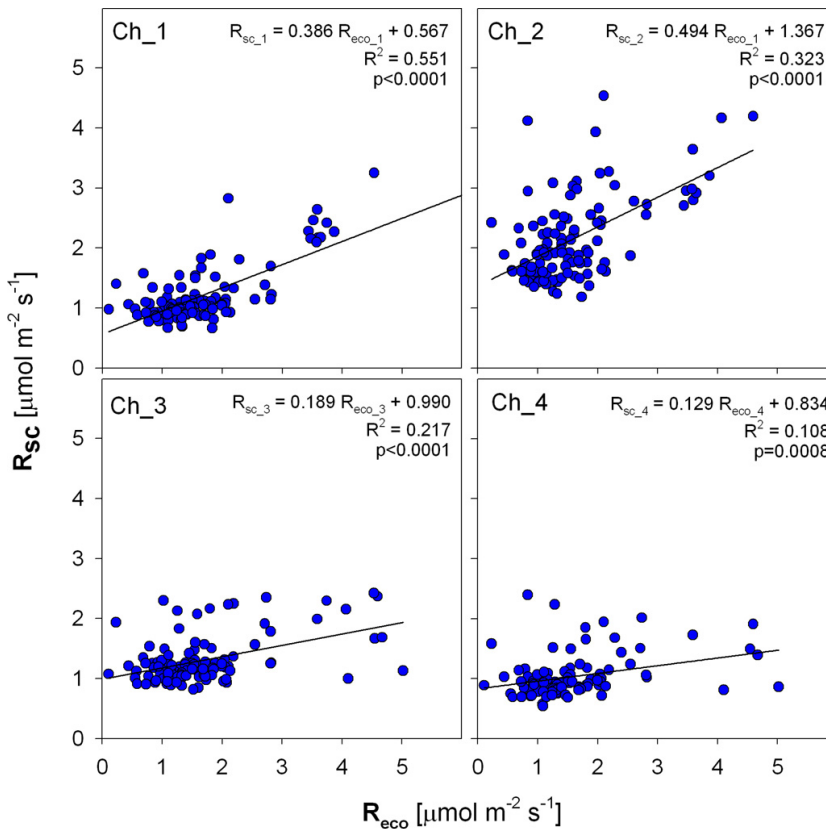

**Fig. 4.** Regressions between soil respiration ( $R_{sc}$ ) and ecosystem respiration ( $R_{eco}$ ) rates as measured by the automated open (chamber) system, and the eddy technique, respectively. Data for chambers in vegetation gaps (Ch1 and Ch2) and trenched plots (Ch3 and Ch4) are shown. Only original (not gapfilled) storage corrected and  $u^*$ -filtered ( $u^* > 0.1 \text{ m.s.l.}$ ) eddy data (half hourly averages) were used in the regression.

**Carbon balance of surfaces vs. ecosystems**

Z. Nagy et al.

Title Page

Abstract Introduction

Conclusions References

Tables Figures

◀ ▶

◀ ▶

Back Close

Full Screen / Esc

Printer-friendly Version

Interactive Discussion

Discussion Paper | Discussion Paper | Discussion Paper | Discussion Paper | Discussion Paper

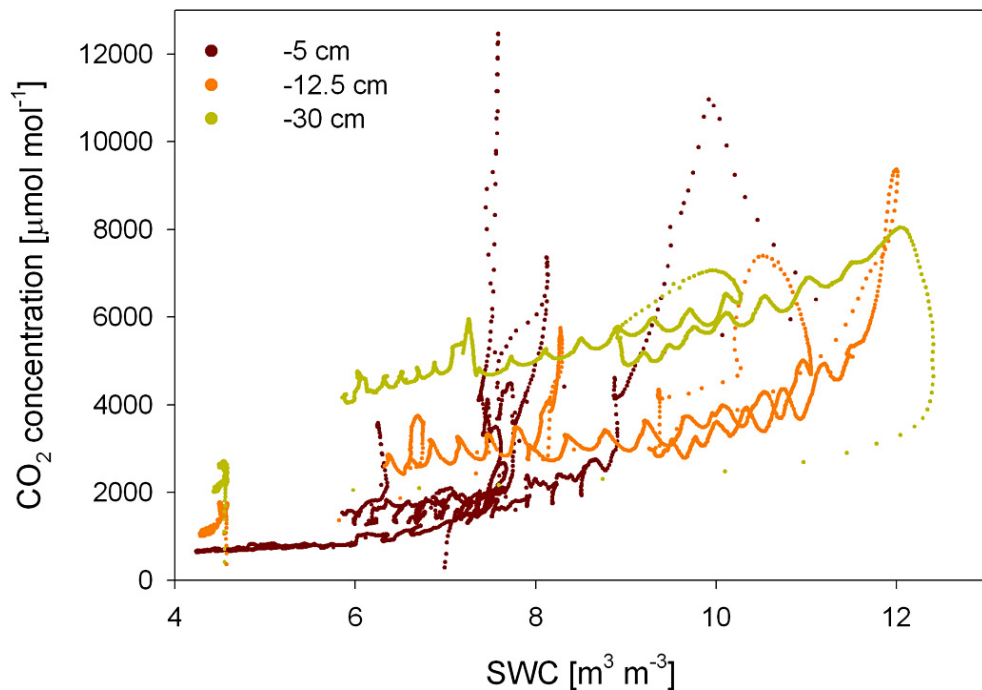
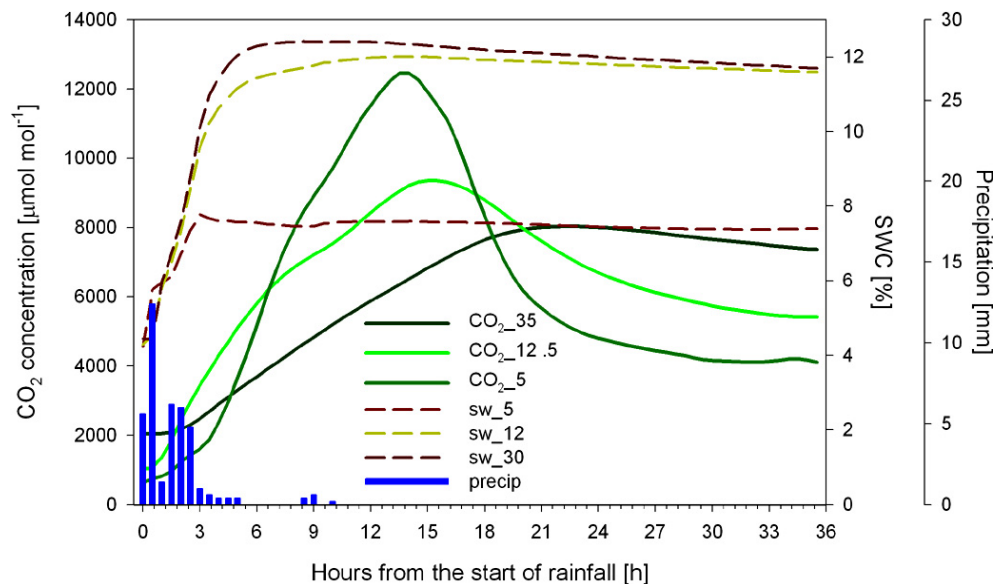

**Fig. 5.** Dependence of CO<sub>2</sub> concentrations on volumetric soil water content at three measurement depths during the summer, 2009. Diurnal cycles (probably due to daily temperature changes) and occasional peaks of CO<sub>2</sub> concentration (after rain events) superposed on the relationship are shown.



## Carbon balance of surfaces vs. ecosystems

Z. Nagy et al.



**Fig. 6.** Time course of CO<sub>2</sub> concentrations and SWC at the three depths after a rain event (at 4th of August, also shown in Fig. 8) and half-hourly precipitation sums for the rain event.

Title Page

Abstract

Introduction

Conclusions

References

Tables

Figures

◀

▶

◀

▶

Back

Close

Full Screen / Esc

Printer-friendly Version

Interactive Discussion



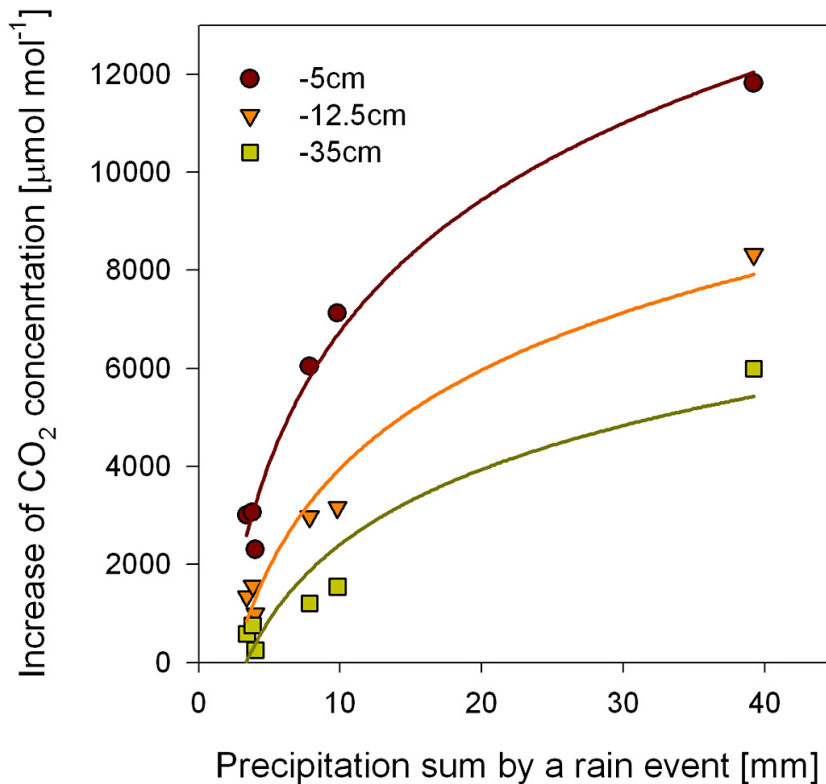

**Fig. 7.** Increase of CO<sub>2</sub> concentration due to different precipitation sums after the summer drought period in August and start of September. Differences between CO<sub>2</sub> concentration maxima (as measured after the rain events) and CO<sub>2</sub> concentrations in the half hour prior to the rain at the three measurement depths are presented.

Title Page

Abstract

Introduction

Conclusions

References

Tables

Figures

◀

▶

◀

▶

Back

Close

Full Screen / Esc

Printer-friendly Version

Interactive Discussion



Carbon balance of surfaces vs. ecosystems

Z. Nagy et al.

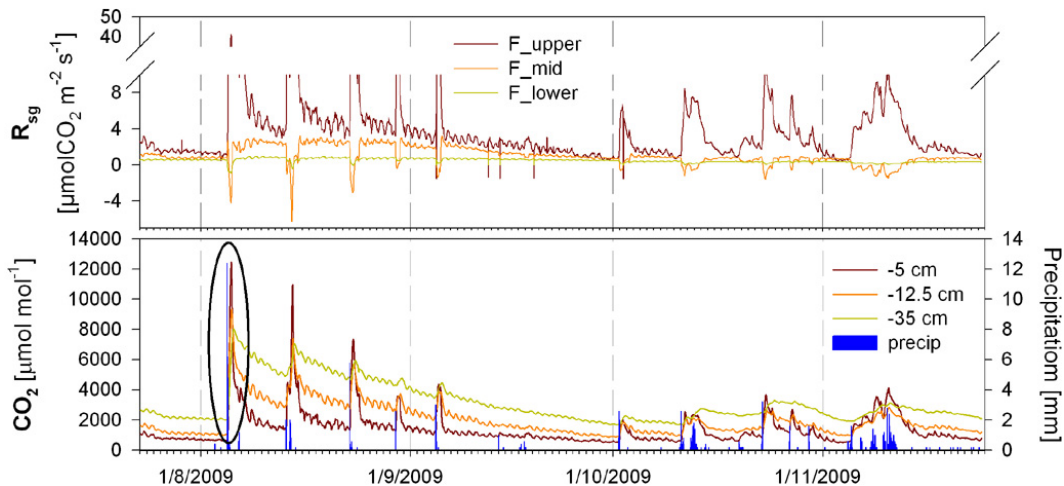

**Fig. 8.** Time course of soil respiration rates at three soil depths (see Table 2) during drought in summer and autumn recovery (downward fluxes have negative signs, upper graph) and CO<sub>2</sub> concentration within the soil profile at 5, 12.5 and 35 cm below ground, respectively and course of precipitation events (lower graph).

Discussion Paper | Discussion Paper | Discussion Paper | Discussion Paper | Discussion Paper

Title Page

Abstract

Introduction

Conclusions

References

Tables

Figures

◀

▶

◀

▶

Back

Close

Full Screen / Esc

Printer-friendly Version

Interactive Discussion



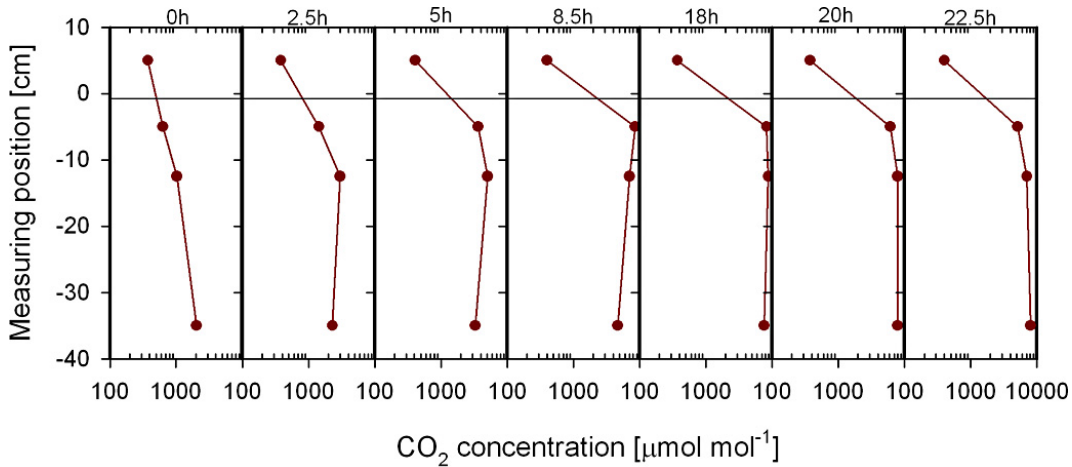

**Fig. 9.** CO<sub>2</sub> concentration profiles within (and 5 cm above) the soil after the start of a rain event (also shown in Fig. 6).

**Carbon balance of surfaces vs. ecosystems**

Z. Nagy et al.

Discussion Paper | Discussion Paper | Discussion Paper | Discussion Paper | Discussion Paper

Title Page

Abstract Introduction

Conclusions References

Tables Figures

◀ ▶

◀ ▶

Back Close

Full Screen / Esc

Printer-friendly Version

Interactive Discussion



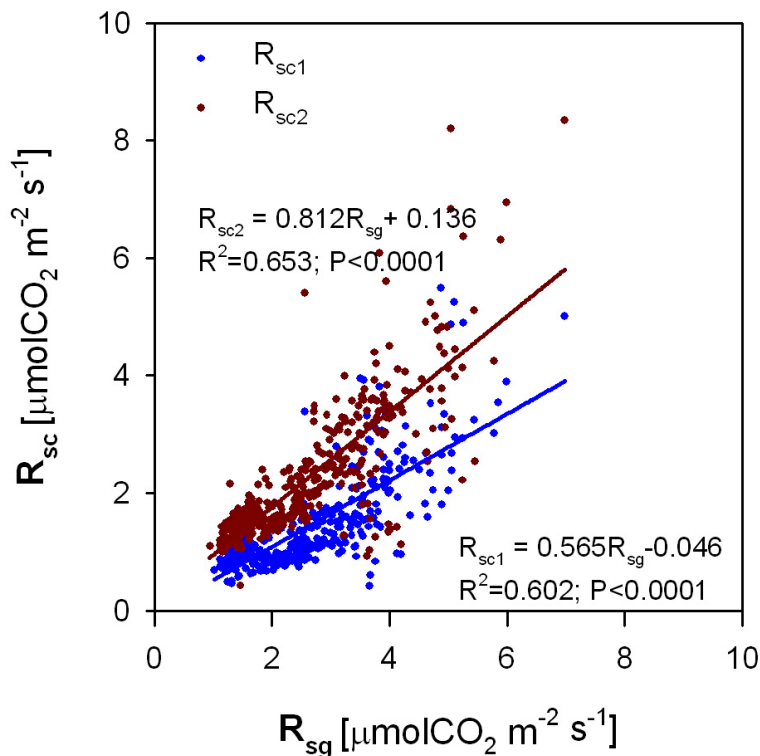

**Fig. 10.** Soil respiration as measured by the gradient method at the surface ( $R_{sg}$ ) vs.  $R_{sc}$  (non-trenched, data sets of the two chambers are separated,  $R_{sc1}$  and  $R_{sc2}$ ). Paired ( $R_{sg}$  and  $R_{sc}$ ) data were used for fitting.  $R_{sg}$  data during periods of inversion of concentration gradients within the soil profile (after rains) were excluded used from the regression.

Title Page

Abstract Introduction

Conclusions References

Tables Figures

◀ ▶

◀ ▶

Back Close

Full Screen / Esc

Printer-friendly Version

Interactive Discussion





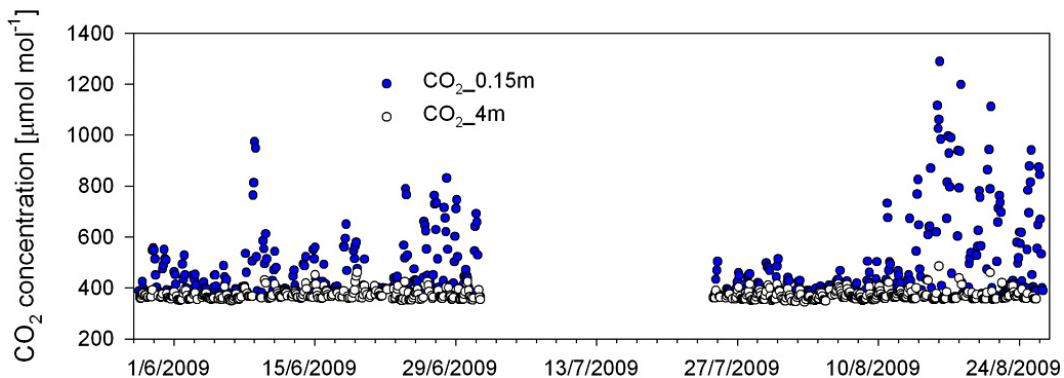

**Fig. 11.** CO<sub>2</sub> concentrations at the eddy measurement height (4 m) and at 0.15 m above ground level, respectively.

**Carbon balance of surfaces vs. ecosystems**

Z. Nagy et al.

Title Page

Abstract Introduction

Conclusions References

Tables Figures

◀ ▶

◀ ▶

Back Close

Full Screen / Esc

Printer-friendly Version

Interactive Discussion

