

Technical Note: A minimally-invasive experimental system for $p\text{CO}_2$ manipulation in plankton cultures using passive gas exchange (Atmospheric Carbon Control Simulator)

Formatted: Font: Italic

5 Brooke A. Love¹, M. Brady Olson¹, Tristen Wuori¹

¹Shannon Point Marine Center, Western Washington University, 1900 Shannon Point Drive, Anacortes, WA, 98221, U.S.A.

Correspondence to: Brooke A. Love (Brooke.Love@wwu.edu)

10

Abstract. As research into the biotic effects of ocean acidification has increased, the methods for simulating these environmental changes in the laboratory have multiplied. Here we describe the atmospheric carbon control simulator (ACCS) for the maintenance of plankton under controlled $p\text{CO}_2$ conditions, designed for species sensitive to the physical disturbance introduced by bubbling of cultures and for studies involving trophic interaction. The system consists of gas mixing and equilibration components, coupled with large volume atmospheric simulation chambers. These chambers allow gas exchange to counteract the changes in carbonate chemistry induced by the metabolic activity of the organisms. The system is relatively low cost, very flexible, and when used in conjunction with semi-continuous culture methods, increases the density of organisms kept under realistic conditions, increases the allowable time interval between dilutions, and/or decreases the metabolically driven change in carbonate chemistry during these intervals. It accommodates a large number of culture vessels, which facilitate multi-trophic level studies and allow the tracking of variable OA-responses within and across plankton populations to ocean acidification. It also includes components that increase the reliability of gas mixing systems using mass flow controllers.

15

20

1 Introduction

Ocean Acidification (OA) is the process by which increasing atmospheric CO_2 leads to increasing dissolved CO_2 in marine waters and the suite of chemical and biological responses driven by this change. Manipulative OA research has increased dramatically over the last decade, and while the scientific community has begun to set standards for data acquisition and experimental design (Cornwall and Hurd, 2015; Dickson et al., 2007; Riebesell et al., 2010)(Cornwall and Hurd, 2015; Dickson et al., 2007; Riebesell et al., 2010), experimental approaches remain diverse because of the wide scope and variety of questions. While many innovative systems are in use, most are not well suited to relatively long-term maintenance of organisms sensitive to continuous bubbling, or cannot accommodate a large number of culture vessels. These are both key characteristics for cross-trophic level or cross generational studies in plankton, e.g. tracking ontogenesis of crustacean zooplankton populations. In addition, static control of chemistry has been criticized (Wahl et al., 2015b)(Wahl et al., 2015b) and systems which are capable of simulating natural variability in conditions are of particular interest.

25

30

The Atmospheric Carbon Control Simulator (ACCS) uses passive gas exchange to simulate the effect of atmospheric exchange in modulating the effects of photosynthesis and respiration on surface water chemistry without undue physical disturbance of delicate planktonic organisms. This approach mimics real conditions in surface and near shore waters where the disequilibrium caused by photosynthesis and respiration is subject to partial re-equilibration through air sea gas exchange. The ACCS is particularly suited for phytoplankton and zooplankton work because it helps maintain carbonate chemistry with minimal physical stress, and accommodates numerous culture vessels, which are useful in tracking variability associated with zooplankton feeding and reproductive metrics. The system is not limited to passive gas exchange for carbonate chemistry

35

40

Formatted: Subtle Emphasis, English (United Kingdom)
Formatted: Subtle Emphasis, English (United Kingdom),
Superscript/ Subscript

control. Direct bubbling can be used to maintain cultures or to pre-equilibrate media for semi-continuous cultures (described below). The ACCS is designed to accommodate differing trophic levels though its ability to accommodate culture vessels of varying number, size and shape, which is not possible in many other systems. The ACCS can also be used with and differing levels of desired carbonate control, re-equilibration, or metabolically driven cycling by changing the biomass concentration in the vessels (which is typical in many systems), but also by controlling the surface area to volume ratios in the cultures and therefore the efficiency of re-equilibration with the supplied atmosphere.

On the broadest scale, experimental approaches to studying OA are classified as microcosms or mesocosms. Mesocosm studies have increased in number in recent years and are well suited to address questions about OA effects on biological communities, while work in microcosms has been criticized because small volumes may have increased enclosure effects and limited realism (Hendriks et al., 2010; Stewart et al., 2013; Wernberg et al., 2012). Although the ACCS is a microcosm system, and has limited potential for realistic simulation of the complexities of community dynamics in a changing ocean, microcosms do have a strong role to play in elucidating the underlying mechanisms that drive those dynamics. The detailed species and interspecies level effects observed in microcosms can be coupled with whole community experiments or observations of natural systems and enhance the interpretation of both types of study (e.g. Webb et al., 2016).

Many studies of planktonic organisms (particularly autotrophs) employ dilute batch culture, where seawater media pre-conditioned to the appropriate chemistry is inoculated at a low density, sealed, and allowed to grow for a limited period of time (e.g. Eberlein et al., 2016; Hoins et al., 2016; Wilcox-Freeburg et al., 2013; Zhang et al., 2015)(Eberlein et al., 2016; Hoins et al., 2016; e.g. Wilcox-Freeburg et al., 2013; Zhang et al., 2015). Changes in water chemistry can exceed 1 pH unit and 15% of DIC during the course of the batch culture when biomass is high or duration is long (Brutemark et al., 2015). Dilute batch culture systems are not well suited for zooplankton studies because cultures are subject to gas exchange each time they are opened for feeding, and dilute cultures of prey can cause encounter rates to limit growth and grazing rates of zooplankton.

A common modification of this batch technique is to bubble CO₂/air mixtures directly into the culture vessels (Kremp et al., 2012; Neale et al., 2014; Talmage and Gobler, 2009)~~A common modification of this batch technique is to bubble CO₂/air mixtures directly into the culture vessels (Kremp et al., 2012; Neale et al., 2014; Talmage and Gobler, 2009).~~ This allows CO₂ and O₂ to re-equilibrate with target concentrations constantly over the course of the experiment. Plankton cultures aerated in this way can achieve somewhat higher densities while still maintaining carbonate chemistry, but this is not appropriate for organisms which are sensitive to turbulence and the shear stress that is induced by bubbling (Gifford, 1993; Riebesell et al., 2010; Shi et al., 2009; Wolfe et al., 2002). We observed possible detrimental effects of bubbling, including reduced growth rates and formation of aggregates during culturing of autotrophic dinoflagellates which were resolved when cells were cultured under passive gas exchange conditions (unpubl. data). Direct bubbling of cultures also dampens or eliminates diurnal cycling in carbonate chemistry, which may not be desirable.

Field Code Changed

75 Several systems are in use which modify the carbonate system by active control of the introduction of CO₂ into the water, activating CO₂ addition only when pH is above the set point for a given treatment (e.g. [Hoffmann et al., 2013](#); [Isari et al., 2016](#); [MacLeod et al., 2015](#); [Wilcox-Freeburg et al., 2013](#))(~~[Hoffmann et al., 2013](#); [Isari et al., 2016](#); [MacLeod et al., 2015](#); e.g. [Wilcox-Freeburg et al., 2013](#)~~). These systems have several advantages, including little to no mechanical stress, and the potential to control diurnal chemical cycles. They may be batch or flow through in nature. One drawback is that each culture vessel usually requires its own independent pH control circuit or valve port, which limits the number of replicates or treatments
80 which can reasonably be accommodated.

Addition of small amounts of water saturated with CO₂ is also an effective method to gently increase $p\text{CO}_2$ ([Garzke et al., 2016](#); [Paul et al., 2016](#); [Riebesell et al., 2010](#); [Runge et al., 2016](#)), but when applied to microcosms, must be coupled with semi-continuous techniques to avoid the limitations noted for batch culture techniques described above.

In semi-continuous cultures, a portion of the volume is periodically replaced with fresh media of the appropriate chemistry in order to maintain cultures in exponential growth and semi-static population abundance ([Feng et al., 2008](#); [Fu et al., 2007](#); [Hutchins et al., 2007](#))(~~[Feng et al., 2008](#); [Fu et al., 2007](#); [Hutchins et al., 2007](#)~~). In addition to being suitable for plankton populations sensitive to mechanical stress, semi-continuous culturing allows for repeated monitoring of chemical and biological factors through use of the volume removed from experimental vessels upon dilution. Semi-continuous culture employs frequent dilutions, or low biomass concentrations to avoid metabolically driven changes in carbonate chemistry.
85 Resource availability, biomass concentrations and metabolic rates determine the dilution interval, which can vary from daily dilutions to every 4 days ([Cripps et al., 2016](#); [Gao et al., 2009](#); [Hildebrandt et al., 2016](#); [Kurihara et al., 2004](#); [Vehmaa et al., 2012](#); [Webb et al., 2016](#); [Xu and Gao, 2015](#))(~~[Cripps et al., 2016](#); [Gao et al., 2009](#); [Hildebrandt et al., 2016](#); [Kurihara et al., 2004](#); [Vehmaa et al., 2012](#); [Webb et al., 2016](#); [Xu and Gao, 2015](#)~~).

Gas exchange has been used as a supplementary control mechanism in microcosms ([Müller et al., 2012](#); [Webb et al., 2016](#)),
95 flow through systems ([Fangue et al., 2010](#)) and mesocosms ([Garzke et al., 2016](#); [Horn et al., 2016](#)), and as a primary control mechanism in one mesocosm ([Wahl et al., 2015a](#)). The ACCS employs passive gas exchange as a modification to the semi-continuous method. Culture vessels are maintained in a large volume chamber with a controlled atmosphere between water changes. This modification can reduce the necessary frequency of water changes and/or increase the allowable biomass density given an acceptable range of biological perturbation to the carbonate chemistry.

100 2 Description of System:

The main components of the ACCS are (1) gas mixing, (2) gas distribution, (3) gas measurement, (4) equilibration and atmospheric simulation chambers, (5) verification of $p\text{CO}_2$ through discrete measurements (Figure 1).

2.1 Gas mixing: The gas mixing system is similar to many others and is described in detail in the supplementary material.

105 In short, compressed air passes through self-regenerating molecular sieves to strip out CO₂, and then flows to a set of mass

Formatted: Subtle Emphasis

Formatted: Subtle Emphasis, Not Superscript/ Subscript

Formatted: Subtle Emphasis

Formatted: Subtle Emphasis, Not Superscript/ Subscript

flow controllers (MFCs) at constant pressure. Research grade CO₂ feeds a second set of MFCs, and the two streams mix to provide precisely controlled CO₂/air gas mixtures to each distribution channel. A set of back pressure regulators maintain a steady pressure on the downstream side of the MFCs. These are paired with typical two stage regulators on the upstream side. This ensures a constant pressure drop across the controllers, resulting in steady flow rates.

110

2.2 Gas Distribution: The mixed gas enters a manifold with six adjustable flow meters for each distribution channel. These allow the user to control and direct the flow of gas to any of the equilibration or atmospheric simulation chambers. Each distribution channel is equipped with a pressure gauge, which allows the user to ensure that downstream pressure does not exceed the set point of the backpressure regulators, thereby decreasing the pressure drop across the MFCs.

115

2.3 Equilibration and atmospheric simulation: After humidification (to minimize evaporative losses from culture vessels), gas mixtures flow to either an equilibration tank or an atmospheric simulation chamber. Pre-conditioning of media is achieved in equilibration tanks (15 L carboys) by continuous bubbling through fine pore air-stones. Inlet and outlet gas lines are connected to barbed fittings in the lids of these carboys to allow treatment air to enter and for head space gas to exit and be monitored for CO₂, which ensures water equilibration. The large atmospheric simulation chambers (120 L volume, 70 cm x 50 cm x 40 cm) are constructed of clear acrylic with inlet and outlet lines and one hinged side for easy access. ~~The chambers hatch. They~~ can be maintained under static or varying temperature and light conditions. The controlled atmosphere supplied to these chambers allows gas exchange to offset metabolically driven changes in water chemistry. ~~in planktonic cultures that will not normally tolerate direct bubbling.~~

120

125

Using semi-continuous techniques, numerous culture vessels can be maintained in each chamber. There is a removable perforated clear acrylic shelf which allows for a large number of smaller vessels to be accommodated, without impeding air flow unduly. 30 jars (500 ml) were haphazardly placed within each of the chambers to culture copepods in the studies described here. Taller vessels can easily be accommodated when the shelf is removed. For example, we have used 6 large (2 L) Erlenmeyer flasks in one chamber of algal cultures, or up to 16 2 L Nalgene bottles. Culture vessels can vary in size, though a practical limit may be reached as to how many can be diluted per day. Daily operation consists of the following basic procedures: 1) Sample the gas streams to ensure they are on target (see section 2.4). 2) Remove vessels from the chambers, wiping away any condensation, and filling the humidifiers at this time. 3) Carry out a semi-continuous dilution for each, making sure to start fresh water equilibrating. 4) Haphazardly replace the culture vessels in the atmospheric simulation chambers. When the chamber is first sealed it may be beneficial to divert all possible gas flow temporarily to that chamber to flush it out and achieve the appropriate atmosphere more quickly. 5) Carry out analyses on water and/or organisms sampled from the culture vessels.

130

135

140 ~~Using semi-continuous techniques, numerous culture vessels can be maintained in each chamber.~~ Alternatively, for populations that are not sensitive to mechanical stress, direct bubbling is possible. A flow control manifold placed in the chamber distributes gas from the chamber inlet into the culture vessels. Intermediate configurations including both direct bubbling and passive gas exchange are also possible, maximizing efficient use of the gas streams.

145 **2.4 Verification of $p\text{CO}_2$:** The $p\text{CO}_2$ of the gas entering the manifold or exiting each of the distribution channels can be quantified (Licor 820). Gas entering the CO_2 sensor is dehumidified by passing through a nafion drying tube supplied with a counter flow around the tube of the dry air from the compressor. This reduces interference from water vapour in the infra-red measurement technique.

150 Carbonate chemistry parameters are measured frequently by subsampling cultures or using the displaced volume from dilutions. Here, we use daily spectrophotometric pH (Dickson et al., 2007)(~~Dickson et al., 2007~~) and total dissolved inorganic carbon (DIC) measurements (Apollo Sci-Tech), supplemented by periodic open cell Gran titrations for total alkalinity (Dickson et al., 2007) and calculate the remaining parameters using the excel version of carbonate system calculation software,~~(Dickson et al., 2007) and calculate the remaining parameters using~~ CO_2sys (Lewis and Wallace, 1998). Details of these methods are available in the supplementary materials.

155 3 Gas Exchange Effects

The primary aspect that differentiates the ACCS from other OA experimental approaches is the prominent use of controlled atmospheres. Movement of CO_2 across the air/water interface in culture vessels in the ACCS helps keep pH and $p\text{CO}_2$ and $p\text{CO}_2$ closer to target values than in a simple batch or semi-continuous approach. While this is not very clear when comparing across studies with different organisms, volumes and $p\text{CO}_2$ (Table 1), it can be demonstrated by the effect of surface area to volume on change in pH in batch cultures.

160 When square cross section flasks are filled to 90%, 70% and 50% of capacity, surface area to volume ratios increase accordingly (90, 116 and 162 $\text{cm}^2 \text{L}^{-1}$ respectively). As photosynthesis draws down CO_2 in batch cultures of *Emiliana huxleyi*, flasks with the highest surface area to volume exhibit the smallest departures in pH from the media blanks (Figure 2). This effect is most pronounced when there is a large gradient across the surface, as in the later stages of these batch cultures. Cell density in these cultures exceeds 1×10^5 cells ml^{-1} on day 3 and 8×10^5 cells ml^{-1} on day 5. Additional testing in the ACCS showed that under cell densities typical in our semi-continuous culture (about 1×10^5 *Emiliana huxleyi* cells ml^{-1}), carbon drawdown was reduced by 20 to 30 percent by passive gas exchange in flasks open to the atmospheric simulation chamber, compared to cultures that were kept capped. While the addition of a gas exchange element to semi-continuous culture increases the realism of the system, the ACCS does not achieve a fully realistic gas exchange scenario. For instance,

170 wind speed plays a major role in the parameterization of gas exchange rates in the field (e.g. Raymond and Cole, 2001;

Formatted: Subtle Emphasis

Formatted: Subtle Emphasis, Not Superscript/ Subscript

Formatted: Subtle Emphasis

Formatted: Subtle Emphasis, Not Superscript/ Subscript

Formatted: Subscript

Formatted: Subtle Emphasis

Formatted: Subtle Emphasis, Not Superscript/ Subscript

Formatted: Superscript

Wanninkhof, 2014). While there is some air flow in the atmospheric simulation chambers, it is probably low compared to field conditions and gas exchange rates are therefore somewhat muted.

4 Performance

~~This system is capable of maintaining a large number of plankton cultures close to their target $p\text{CO}_2$ conditions.~~ Carbonate chemistry is steady over time, and treatment differences are stable, which allows cultures to acclimate to given conditions for many days (Figure 3). Semi-continuous cultures do show some effect of biological modification of the mean $p\text{CO}_2$ values, which are reduced in algal cultures and increased in zooplankton cultures relative to the pre-equilibrated media. Despite these effects, the ACCS maintains strong treatment separation (Figure 4) (See table S1 for the full suite of carbonate chemistry parameters). The average difference between the pre-equilibrated media and cultures after 24 hours of growth was 75 μatm CO_2 during the experiment illustrated in Figure 3. ~~These measurements represent the greatest departure of conditions from the pre-equilibrated media because samples were taken just before dilution with fresh media.~~ Average culture conditions over 24 h are likely closer to that of the pre-equilibrated media, however the timing and magnitude of these differences depend on the metabolic activity in the culture, and the timing of the dilutions relative to diurnal cycling. Details for the 4 experiments outlined in this study are reviewed in Table 2. These experiments are a representative subset of at least 20 more than a dozen experiments which have been carried out in the ACCS but students and faculty.

Use of the ACCS with semi-continuous culture and passive gas exchange allows a diurnal cycle to develop in cultures. During the light period, $p\text{CO}_2$ drops in algal cultures, and rises with net respiration during dark periods. Experiments in which we monitored carbonate chemistry in detail over 24 hours showed that during an 8-hour dark period, $p\text{CO}_2$ increased on average 10-20 μatm in cultures of *Emiliania huxleyi*, and average drawdown over an 8-hour light period were 30-60 μatm CO_2 . This corresponds to a light period change in pH of about 0.03 and about 0.4 % change in DIC. These differences are consistent in magnitude with the increases in $p\text{CO}_2$ for passively maintained mixed cultures of copepods and their prey over 24 hours in the ACCS (Table 1). These changes in pH of between 0.02 and 0.05 pH units, correspond to $p\text{CO}_2$ increases between 50 and 100 ppm CO_2 over the course of 24 hours. The daily dilution ensures that this cycle in $p\text{CO}_2$ remains centered around a steady average value and is not overwhelmed by increased biomass or metabolic activity in the culture vessels over time.

This level of diurnal variability is comparable to that found in some of the more stable natural systems. Hofmann et al. (2011) deployed pH sensors in a range of habitats and found short term variability of about 0.02 in open ocean environments, and ranging up to greater than 0.5 in some estuarine and reef habitats. (Hofmann et al., 2011) ~~deployed pH sensors in a range of habitats and found short term variability of about 0.02 in open ocean environments, and ranging up to greater than 0.5 in some estuarine and reef habitats.~~ This variability can be driven by mixing, advection, upwelling, and community metabolism.

Formatted: Subtle Emphasis

Formatted: Subtle Emphasis, Not Superscript/ Subscript

Formatted: Subtle Emphasis

Formatted: Subtle Emphasis, Not Superscript/ Subscript

Formatted: Subtle Emphasis

Formatted: Subtle Emphasis, Not Superscript/ Subscript

Formatted: Font: Italic

Formatted: Subtle Emphasis

Formatted: Subtle Emphasis, Not Superscript/ Subscript

Formatted: Subtle Emphasis

Formatted: Subtle Emphasis, Not Superscript/ Subscript

Formatted: Subtle Emphasis

Formatted: Subtle Emphasis, Not Superscript/ Subscript

Biomass density and water residence time are two major factors which govern the magnitude of pH variability in natural settings and which can be approximated in semi-continuous culture.

205 Metabolically driven changes in microcosm carbonate chemistry can be large when allowed to go unchecked. For instance, in the case of Villafane (2015) rapid growth rates in their high $p\text{CO}_2$ treatment resulted in increases in pH of about 0.4 units per day after they were reset to a nominal value each morning. This level of variability rivals that of some of the most dynamic marine systems, such as upwelling sites in upwelling zones or estuarine systems which can exhibit high frequency pH variability in ranges of 0.4 to 0.99 (Hofmann et al., 2011).~~This level of variability rivals that of some of the most dynamic marine systems.~~
210 ~~marine systems~~: Dilution of cultures is a rough analogue of water exchange or residence time in a given habitat. When water changes or dilutions have a longer time interval, a change in pH of 0.15 to 0.5 between water changes is common (Table 1). This corresponds to approximately a 400 – 800 μatm difference in $p\text{CO}_2$, which rivals or exceeds the difference between treatments in many experiments.

Formatted: Subtle Emphasis

Formatted: Subtle Emphasis, Not Superscript/ Subscript

215 In the ACCS, active control of biomass and turnover of water through dilution is coupled with gas exchange to keep the variability within realistic bounds, and to enhance the realism of the experimental system. When biomass in culture and the surface area to volume ratios are moderate, the stability of pH in the ACCS is comparable to other experiments using semi-continuous culturing but no subsequent gas exchange (Table 1). When operated with care and attention to the considerations detailed below, very tight carbonate chemistry control is possible (e.g. experiment 4). All semi-continuous methods can modify
220 the variability in carbonate conditions by changing the biomass concentration in culture. The ACCS can also increase or decrease variability by modulating the effects of gas exchange on the cultures (Figure 2).

Formatted: Subtle Emphasis

Formatted: Subtle Emphasis, Not Superscript/ Subscript

5 Considerations

Water vapor can exchange across the surface as well as CO_2 , resulting in evaporation if air in the atmospheric simulation chamber is dry. In order to humidify air, gas streams can pass through membrane based nafion humidifiers or more simply,
225 air entering the chamber can be bubbled through a column of deionized water. Water changes associated with semi-continuous culturing also help maintain appropriate salinity levels.

The development of a substantial diffusive boundary layer at the air water interface will reduce the rate of gas exchange. Mixing of both the air and water minimizes this effect. Air circulation in the atmospheric simulation chambers is driven by
230 inflow of gas at about 5 L min^{-1} . Automatic stirring of culture vessels that is sufficiently gentle is difficult to achieve in an open vessel and manual stirring requires that the chamber be opened. Early versions of the ACCS incorporated integral gloves for handling vessels without opening the chamber, but they were cumbersome. Therefore, culture vessels are not actively stirred, and boundary layers may develop between mixing of cultures upon feeding or dilution.

235 Air in the chamber is replaced with the room air when opened, and takes some time to be replenished with treatment air. This is particularly important when the chambers are located in an enclosed space such as a walk-in incubator. Lab air in general, and in enclosed spaces where people are working in particular, can quickly achieve very high CO_2 concentrations. $p\text{CO}_2$. Good general ventilation, monitoring of room air $p\text{CO}_2$ and fans that can be activated before chambers are opened is recommended. Scrubbing of room air is also possible, but we found ventilation to be simpler and more effective. The performance of this system has improved over time with the improvements in ventilation and sample handling. When operated with care, it compares favorably to other published results from semi-continuous culturing studies (Table 1).

Formatted: Subtle Emphasis

Formatted: Subtle Emphasis, Not Superscript/ Subscript

6 Advantages

Advantages of this system include the ability to allow diurnal cycles in carbonate chemistry to develop, but also the ability to modulate those effects through gas exchange, as in near shore environments. Depending on the organismal metabolic rates, semi-continuous dilution volumes, and the surface area to volume ratio of the culture vessels, the diurnal cycle can be tuned such that it is similar in magnitude to that in natural systems. The dilution of cultures and gas exchange keep carbonate chemistry close to target values while still allowing relatively dense cultures. It has cost effective gas handling, flexibility, and is suitable for delicate planktonic organisms, including holo- and meroplankton. Vessel $p\text{CO}_2$ is gently controlled via passive gas exchange, or more robust cultures may be bubbled directly.

Formatted: Subtle Emphasis

Formatted: Subtle Emphasis, Not Superscript/ Subscript

250 A key feature of the ACCS is the ability to accommodate a large number of culture vessels. For example, tracking copepod egg production of individual females, or the hatching success and development of egg clutches requires more culture vessels than can be accommodated by most OA experimental methods. The ACCS enables analysis of these metrics, or the tracking of individual breeding crosses or families over time. These kinds of studies get at the variability of responses within a population which is important both in data interpretation and in predicting how adaptation mediates OA response.

255 The addition of backpressure regulators can increase the reliability of mixed gas concentrations. MFCs need a constant pressure drop across the controller to operate correctly. Many system operators do not control pressure downstream of MFCs, and may adjust upstream pressure to counteract pressure changes in the distribution system (Falkenberg et al., 2016). It is imperative that the concentrations of the gas supply remain steady regardless of the state of the airstones in the pre-equilibration tanks or small flow adjustment which can cause cascading effects through pressure changes. The backpressure regulators in the ACCS maintain a pressure of 15 psi on the MFC outlets as long as the downstream pressure does not exceed that value. When paired with 2 stage regulators upstream, which maintain a pressure of 30 psi on the MFC inlets, the back pressure regulators improve MFC performance. The addition of backpressure regulators would benefit any system which uses MFCs.

7 Experimental design considerations

265 Many OA studies have not fully addressed the independence of their replicates in the design or the description of experimental systems (Cornwall and Hurd, 2015). While this system is not immune to these issues, some steps can be taken in its use to minimize these concerns. With six distribution channels for each concentration, one could supply three independent equilibration tanks paired with 3 atmospheric simulation chambers for each $p\text{CO}_2$ treatment (similar to tank array b in Cornwall and Hurd). ~~Atmospheric chamber could~~ ~~A nested design would~~ then be ~~included as a random variable in the~~ ~~appropriate for~~ statistical analysis ~~whereof results from~~ culture vessels ~~are the replicates~~ ~~in those chambers~~. Alternatively, the tanks used for 270 equilibration could be randomly reassigned to different treatments when they are refilled each day, reducing potential issues arising from using a common equilibration tank for all replicates in each treatment. Similarly, atmospheric simulation chambers can be easily reassigned to different treatments through the course of the experiment. Preliminary tests in the system showed no effect of atmospheric chamber on algal cultures, but contamination or other problems could differentially affect the chambers and confound results if ~~there is only one~~ chamber ~~per~~ ~~and~~ treatment ~~condition~~ ~~conditions are identical~~. The greater 275 the number of experimental conditions, the less flexibility there is to increase independence of experimental units (culture vessels in this case). For instance, if the design requires three temperatures for each of 3 $p\text{CO}_2$ levels, then equilibration can be carried out inside the atmospheric simulation chamber, and 2 chambers can be assigned to each $p\text{CO}_2$ /Temperature condition.

Formatted: Subtle Emphasis

Formatted: Subtle Emphasis, Not Superscript/ Subscript

Formatted: Subtle Emphasis

Formatted: Subtle Emphasis, Not Superscript/ Subscript

Formatted: Subtle Emphasis

Formatted: Subtle Emphasis, Not Superscript/ Subscript

8 Conclusion

280 The flexible design of the ACCS has proven to be effective in experiments with a wide variety of organisms, including bacterioplankton, phytoplankton, micro- and meso- zooplankton, and larval invertebrates (Buckham, 2015; Christmas, 2013; Kendall, 2015; McLaskey et al., 2016; Siu et al., 2014; Still, 2016; Wuori, 2012). It is particularly designed for the maintenance of organisms which are sensitive to bubbling, and for increasing the realism which can be achieved in a microcosm through diurnal fluctuations and natural gas exchange processes.

Field Code Changed

285 Data Availability

All data are either available in the supplementary material (data for Figure 2 ~~and general carbonate chemistry parameters~~) or at the BCO-DMO data repository.

Author Contribution

290 B. Love was the lead on design and construction of the system, supervision and execution of the initial testing, system improvements maintenance and trouble shooting. M.B. Olson collaborated on these same activities. T. Wuori carried out

initial testing, including surface area to volume experiments. B. Love drafted the manuscript with primary editorial assistance from M.B. Olson and helpful commentary from T. Wuori.

Competing Interests

The authors declare that they have no conflict of interest.

295 **Acknowledgements**

We are grateful for the support of the faculty and staff of the Shannon Point Marine Center, for accommodating and enhancing the ever expanding scope of the ocean acidification lab. Scientific Technical Services built and repaired countless devices for this project. Several undergraduate students contributed through research projects, including Sabelo Duley, Daniel Hernandez, Julius Allison, and Daniel Hodge. These students were supported by the NSF Research Experience for Undergraduates and
300 Multicultural Initiative in Marine Science Undergraduate Programs. This work was funded through National Science Foundation awards OCE 0961229 and OCE 1220664.

References

- Brutemark, A., Engström-Öst, J., Vehmaa, A. and Gorokhova, E.: Growth, toxicity and oxidative stress of a cultured cyanobacterium (sp.) under different CO₂/pH and temperature conditions, *Phycol. Res.*, 63(1), 56–63, doi:10.1111/pre.12075,
305 2015.
- Buckham, S.: Ocean acidification affects larval swimming in *Ostrea lurida* but not *Crassostrea gigas*, Thesis, Western Washington University. [online] Available from: <http://cedar.wvu.edu/wwuet/451/>, 2015.
- Christmas, A. M.: Effects of ocean acidification on dispersal behavior in the larval stage of the Dungeness crab and the Pacific Green Shore crab, Western Washington University. [online] Available from: <http://cedar.wvu.edu/wwuet/306/>, 2013.
- 310 Cornwall, C. E. and Hurd, C. L.: Experimental design in ocean acidification research: problems and Solutions, *ICES J. Mar. Sci.*, 73(3), 572–581, 2015.
- Cripps, G., Flynn, K. J. and Lindeque, P. K.: Ocean Acidification Affects the Phyto-Zoo Plankton Trophic Transfer Efficiency, *PLoS One*, 11(4), e0151739, doi:10.1371/journal.pone.0151739, 2016.
- Dickson, A. G., Sabine, C. L. and Christian, J. R.: Guide to best practices for ocean CO₂ measurements, Edited Book, PICES,
315 Sydney., 2007.
- Eberlein, T., Van De Waal, D. B., Brandenburg, K. M., John, U., Voss, M., Achterberg, E. P. and Rost, B.: Interactive effects of ocean acidification and nitrogen limitation on two bloom-forming dinoflagellate species, *Mar. Ecol. Prog. Ser.*, 543, 127–140, doi:10.3354/meps11568, 2016.

- Falkenberg, L. J., Russell, B. D. and Connell, S. D.: Design and performance evaluation of a mesocosm facility and techniques to simulate ocean acidification and warming, *Limnol. Oceanogr. Methods*, 14, 278–291, doi:10.1002/lom3.10088, 2016.
- 320 Fangue, N. A., O'Donnell, M. J., Sewell, M. a., Matson, P. G., MacPherson, A. C. and Hofmann, G. E.: A laboratory-based, experimental system for the study of ocean acidification effects on marine invertebrate larvae, *Limnol. Oceanogr. Methods*, 8, 441–452, doi:10.4319/lom.2010.8.441, 2010.
- Feng, Y., Warner, M. E., Zhang, Y., Sun, J., Fu, F. X., Rose, J. M. and Hutchins, D. A.: Interactive effects of increased pCO₂, temperature and irradiance on the marine coccolithophore *Emiliana huxleyi* (Prymnesiophyceae), *Eur. J. Phycol.*, 43(1), 87–98, doi:10.1080/09670260701664674, 2008.
- 325 Fu, F.-X., Warner, M. E., Zhang, Y., Feng, Y. and Hutchins, D. A.: Effects of increased temperature and CO₂ on photosynthesis, growth, and elemental ratios in marine *Synechococcus* and *Prochlorococcus* (Cyanobacteria), *J. Phycol.*, 43(3), 485–496, doi:10.1111/j.1529-8817.2007.00355.x, 2007.
- 330 Gao, K., Ruan, Z., Villafañe, V. E., Gattuso, J.-P. and Helbling, E. W.: Ocean acidification exacerbates the effect of UV radiation on the calcifying phytoplankter *Emiliana huxleyi*, *Limnol. Oceanogr.*, 54(6), 1855–1862, doi:10.4319/lo.2009.54.6.1855, 2009.
- Garzke, J., Hansen, T., Ismar, S. M. H. and Sommer, U.: Combined Effects of Ocean Warming and Acidification on Copepod Abundance, Body Size and Fatty Acid Content, *PLoS One*, 11(5), e0155952, doi:10.1371/journal.pone.0155952, 2016.
- 335 Gifford, D. J.: Isolation and laboratory culture of marine oligotrichous ciliates, in *Handbook of methods in aquatic microbial ecology*, edited by P. Kemp, B. Sherr, E. Sherr, and J. Cole, pp. 103–108, Lewis Publishers, Boca Raton, FL., 1993.
- Hendriks, I. E., Duarte, C. M. and Alvarez, M.: Vulnerability of marine biodiversity to ocean acidification: A meta-analysis, *Estuar. Coast. Shelf Sci.*, 86(2), 157–164, doi:10.1016/j.ecss.2009.11.022, 2010.
- Hildebrandt, N., Sartoris, F. J., Schulz, K. G., Riebesell, U. and Niehoff, B.: Ocean acidification does not alter grazing in the calanoid copepods *Calanus finmarchicus* and *Calanus glacialis*, *ICES J. Mar. Sci.*, 73(3), 927–936, doi:10.1093/icesjms/fsv226 Contribution, 2016.
- 340 Hoffmann, L. J., Breitbarth, E., McGraw, C. M., Law, C. S., Currie, K. I. and Hunter, K. A.: A trace-metal clean, pH-controlled incubator system for ocean acidification incubation studies, *Limnol. Oceanogr. Methods*, 11, 53–61, doi:10.4319/lom.2013.11.53, 2013.
- 345 Hofmann, G. E., Smith, J. E., Johnson, K. S., Send, U., Levin, L. A., Micheli, F., Paytan, A., Price, N. N., Peterson, B., Takeshita, Y., Matson, P. G., Darse Crook, E., Kroeker, K. J., Gambi, M. C., Rivest, E. B., Frieder, C. A., Yu, P. C. and Martz, T. R.: High-Frequency dynamics of ocean pH: a multi-ecosystem comparison, *PLoS ONE*, 6(12), e28983, doi:10.1371/journal.pone.0028983, 2011.
- Hoins, M., Eberlein, T., Großmann, C. H., Brandenburg, K., Reichart, G.-J., Rost, B., Sluijs, A. and Van de Waal, D. B.: Combined Effects of Ocean Acidification and Light or Nitrogen Availabilities on ¹³C Fractionation in Marine Dinoflagellates, *PLoS One*, 11(5), e0154370, doi:10.1371/journal.pone.0154370, 2016.
- 350 Horn, H. G., Boersma, M., Garzke, J., Loeder, M. G. J., Sommer, U. and Aberle, N.: Effects of high CO₂ and warming on a

- Baltic Sea microzooplankton community, *Ices J. Mar. Sci.*, 73(3), 772–782, doi:10.1093/icesjms/fsv198, 2016.
- Hutchins, D. A., Fu, F.-X., Zhang, Y., Warner, M. E., Feng, Y., Portune, K., Bernhardt, P. W. and Mulholland, M. R.: CO2 control of *Trichodesmium* N2 fixation, photosynthesis, growth rates, and elemental ratios: implications for past, present, and future ocean biogeochemistry, *Limnol. Oceanogr.*, 52(4), 1293–1304, 2007.
- Isari, S., Zervoudaki, S., Peters, J., Papantoniou, G., Pelejero, C. and Saiz, E.: Lack of evidence for elevated CO2-induced bottom-up effects on marine copepods: a dinoflagellate–calanoid prey–predator pair, *ICES J. Mar. Sci.*, 73(3), 650–658, 2016.
- Kendall, K.: Marine microzooplankton are indirectly affected by ocean acidification through direct effects on their phytoplankton prey, Thesis, Western Washington University, Washington. [online] Available from: <http://cedar.wvu.edu/wwuet/448/>, 2015.
- Kremp, A., Godhe, A., Egardt, J., Dupont, S., Suikkanen, S., Casabianca, S. and Penna, A.: Intraspecific variability in the response of bloom-forming marine microalgae to changed climate conditions, *Ecol. Evol.*, 2(6), 1195–1207, doi:10.1002/ece3.245, 2012.
- Kurihara, H., Shimode, S. and Shirayama, Y.: Sub-Lethal Effects of Elevated Concentration of CO2 on Planktonic Copepods and Sea Urchins, *J. Oceanogr.*, 60, 743–750, doi:10.1007/s10872-004-5766-x, 2004.
- Lewis, E. and Wallace, D. W. R.: Program developed for CO2 system calculations, ORNL/CDIAC-105, , 38, 1998.
- MacLeod, C. D., Doyle, H. L. and Currie, K. I.: Technical Note: Maximising accuracy and minimising cost of a potentiometrically regulated ocean acidification simulation system, *Biogeosciences*, 12(3), 713–721, doi:10.5194/bg-12-713-2015, 2015.
- McLaskey, A., J. K., McElhany, P., Olson, M. B., Busch, S., Maher, M. and Winans, A. K.: Development of *Euphausia pacifica* (krill) larvae is impaired under pCO2 levels that are currently observed in the Northeast Pacific, *Mar. Ecol. Prog. Ser.*, 555, 65–78, doi:10.3354/meps11839, 2016.
- Müller, M. N., Beaufort, L., Bernard, O., Pedrotti, M. L., Talec, A. and Sciandra, A.: Influence of CO2 and nitrogen limitation on the coccolith volume of *Emiliana huxleyi* (Haptophyta), *Biogeosciences*, 9, 4155–4167, doi:10.5194/bg-9-4155-2012, 2012.
- Neale, P. J., Sobrino, C., Segovia, M., Mercado, J. M., Leon, P., Cortés, M. D., Tuite, P., Picazo, A., Salles, S., Cabrerizo, M. J., Prasil, O., Montecino, V., Reul, A. and Fuentes-Lema, A.: Effect of CO2, nutrients and light on coastal plankton. I. Abiotic conditions and biological responses, *Aquat. Biol.*, 22, 25–41, doi:10.3354/ab00587, 2014.
- Paul, C., Sommer, U., Garzke, J., Moustaka-Gouni, M., Paul, A. and Matthiessen, B.: Effects of increased CO2 concentration on nutrient limited coastal summer plankton depend on temperature, *Limnol. Oceanogr.*, 61, 853–868, doi:10.1002/lno.10256, 2016.
- Riebesell, U., Fabry, V. J., Hansson, L. and Gattuso, J.: Guide to best practices for ocean acidification research and data reporting, edited by U. Riebesell, V. J. Fabry, L. Hansson, and J. Gattuso, Publications Office of the European Union, Luxembourg., 2010.
- Runge, J., Fields, D., Thompson, C., Shema, S., Bjelland, R., Durif, C., Skiftevsik, A. and Browman, H.: End of the century

- CO₂ concentrations do not have a negative effect on vital rates of *Calanus finmarchicus*, an ecologically critical planktonic species in North Atlantic ecosystems, *ICES J. Mar. Sci.*, 73(3), 937–950, doi:doi:10.1093/icesjms/fsv258, 2016.
- 390 Shi, D., Xu, Y. and Morel, F. M. M.: Effects of the pH / pCO₂ control method on medium chemistry and phytoplankton growth, *Biogeosciences*, 6(7), 1199–1207, doi:10.5194/bg-6-1199-2009, 2009.
- Siu, N., Apple, J. K. and Moyer, C. L.: The Effects of Ocean Acidity and Elevated Temperature on Bacterioplankton Community Structure and Metabolism, *Open J. Ecol.*, 4(8), 434–455, doi:10.4236/oje.2014.48038, 2014.
- Stewart, R. I. A., Dossena, M., Bohan, D. A., Jeppesen, E., Kordas, R. L., Ledger, M. E., Meerhoff, M., Moss, B., Mulder, C., Shurin, J. B., Suttle, B., Thompson, R., Trimmer, M. and Woodward, G.: Mesocosm experiments as a tool for ecological climate-change Research, in *Advances in Ecological Research Vol 48*, edited by G. Woodward, pp. 71–182, Academic Press, London., 2013.
- 395 Still, K.: Microzooplankton grazing , growth and gross growth efficiency are affected by pCO₂ induced changes in phytoplankton biology, Thesis, Western Washington University. [online] Available from: <http://cedar.wvu.edu/wwuet/478/>, 2016.
- 400 Talmage, S. C. and Gobler, C. J.: The effects of elevated carbon dioxide concentrations on the metamorphosis, size, and survival of larval hard clams (*Mercenaria mercenaria*), bay scallops (*Argopecten irradians*), and Eastern oysters (*Crassostrea virginica*), *Limnol. Oceanogr.*, 54(6), 2072–2080, doi:10.4319/lo.2009.54.6.2072, 2009.
- Vehmaa, A., Brutemark, A. and Engström-Öst, J.: Maternal effects may act as an adaptation mechanism for copepods facing pH and temperature changes, *PLoS ONE*, 7(10), e48538, doi:10.1371/journal.pone.0048538, 2012.
- 405 Villafañe, V. E., Valiñas, M. S., Cabrerizo, M. J. and Helbling, E. W.: Physio-ecological responses of Patagonian coastal marine phytoplankton in a scenario of global change: Role of acidification, nutrients and solar UVR, *Mar. Chem.*, 177, 411–420, doi:10.1016/j.marchem.2015.02.012, 2015.
- Wahl, M., Buchholz, B., Winde, V., Golomb, D., Guy-Haim, T., Müller, J., Rilov, G., Scotti, M. and Böttcher, M. E.: A mesocosm concept for the simulation of near-natural shallow underwater climates: The Kiel Outdoor Benthocosms (KOB), *Limnol. Oceanogr. Methods*, 13, 651–663, doi:10.1002/lom3.10055, 2015a.
- 410 Wahl, M., Sawall, Y. and Saderne, V.: How good are we at assessing the impact of ocean acidification in coastal systems? Limitations, omissions and strengths of commonly used experimental approaches with a special emphasis on the neglected role of fluctuations, *Mar. Freshw. Res.* [online] Available from: http://www.publish.csiro.au/view/journals/dsp_journals_pip_abstract_Scholar1.cfm?nid=126&pip=MF14154, 2015b.
- 415 Webb, A. L., Malin, G., Hopkins, F. E., Ho, K.-L., Riebesell, U., Schulz, K., Larsen, A. and Liss, P.: Ocean acidification affects production of DMS and DMSP measured in a mesocosm study and cultures of *Emiliana huxleyi* RCC1229: a comparison of community interactions and laboratory monocultures, *Environ. Chem.*, 13, 314–329, doi:10.1071/EN14268, 2016.
- Wernberg, T., Smale, D. A. and Thomsen, M. S.: A decade of climate change experiments on marine organisms: Procedures, patterns and problems, *Glob. Chang. Biol.*, 18(5), 1491–1498, doi:10.1111/j.1365-2486.2012.02656.x, 2012.
- 420

Wilcox-Freeburg, E., Rhyne, a, Robinson, W. E., Tlusty, M., Bourque, B. and Hannigan, R. E.: A comparison of two pH-stat carbon dioxide dosing systems for ocean acidification experiments, *Limnol. Ocean. Methods*, 11, 485–494, doi:10.4319/lom.2013.11.485, 2013.

425 Wolfe, G. V, Strom, S. L., Holmes, J. L., Radzio, T. and Olson, M. B.: Dimethylsulfoniopropionate cleavage by marine phytoplankton in response to mechanical, chemical, or dark stress, *J. Phycol.*, 38(5), 948–960, doi:10.1046/j.1529-8817.2002.t01-1-01100.x, 2002.

Wuori, T.: The effects of elevated pCO₂ in the physiology of *Emiliana huxleyi*, Thesis, Western Washington University. [online] Available from: <http://cedar.wvu.edu/wwuet/235/>, 2012.

430 Xu, K. and Gao, K.: Solar UV irradiances modulate effects of ocean acidification on the coccolithophorid *Emiliana huxleyi*, *Photochem. Photobiol.*, 91(1), 92–101, doi:10.1111/php.12363, 2015.

Zhang, Y., Bach, L. T., Schulz, K. G. and Riebesell, U.: The modulating effect of light intensity on the response of the coccolithophore *Gephyrocapsa oceanica* to ocean acidification, *Limnol. Oceanogr.*, 60(6), 2145–2157, doi:10.1002/lno.10161, 2015.

435

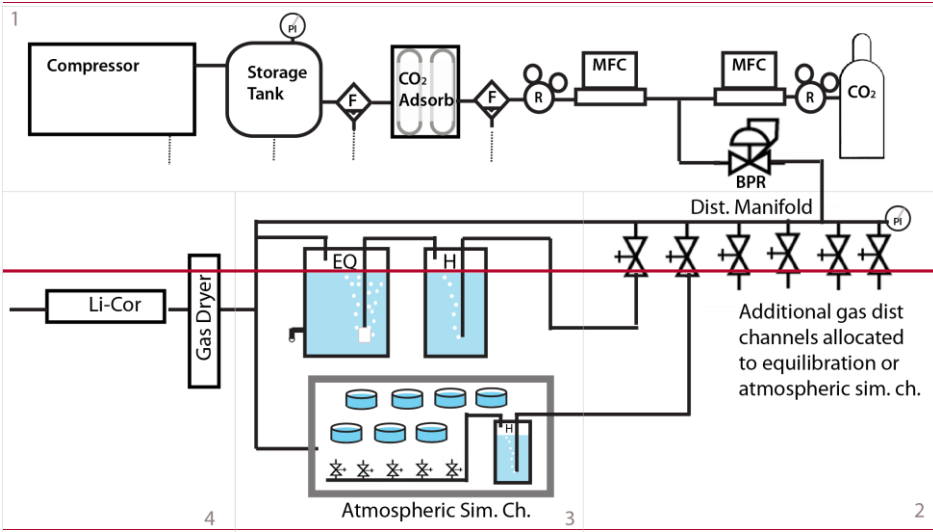
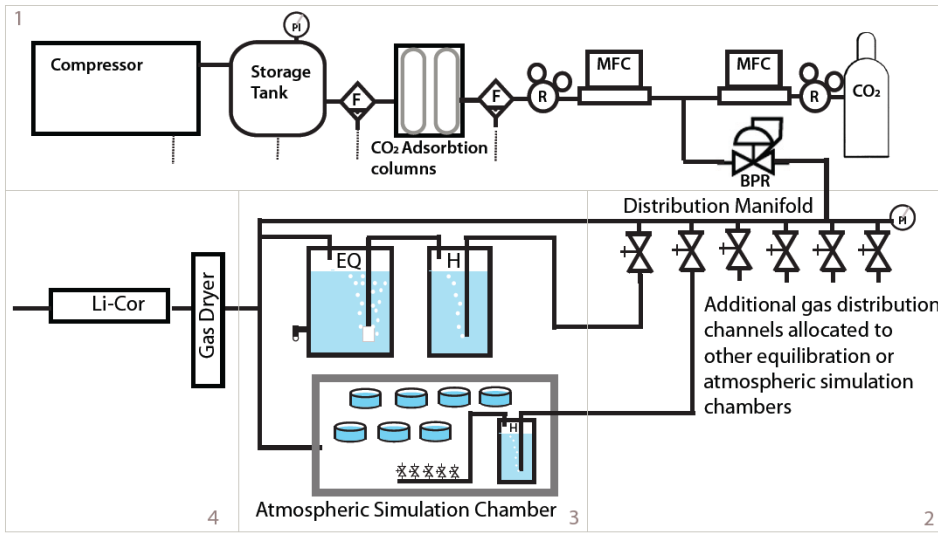

440 **Figure 1:** A general schematic of the system including gas mixing (1), gas distribution (2), equilibration tanks and atmospheric
simulation chambers with temperature control (3), and verification of $p\text{CO}_2$ (4). A pair of MFCs (**Mass Flow Controllers**) is present
for each $p\text{CO}_2$ treatment. The components in 2 and 4 are also repeated for each treatment for up to 9 total equilibration tanks and
up to 9 atmospheric simulation chambers. Abbreviations in the schematic include pressure indication (PI), self-draining filter (F),
regulator (R), back pressure regulator (BPR), humidifier (H), and equilibration tank (EQ). The distribution manifold is plumbed
445 with flow meter valves so each gas distribution channel can be visually checked and adjusted for flow. Dotted lines indicate drain
lines.

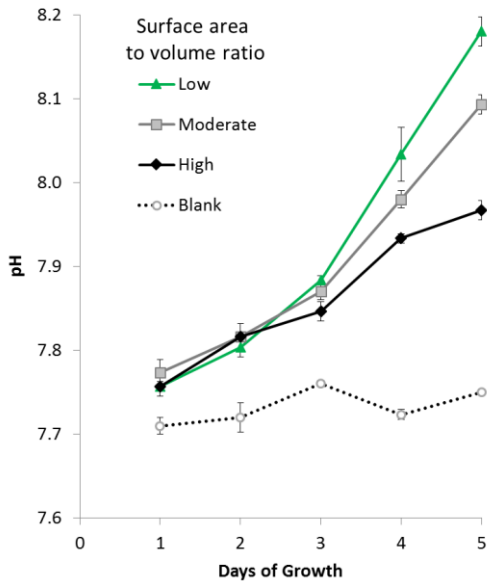

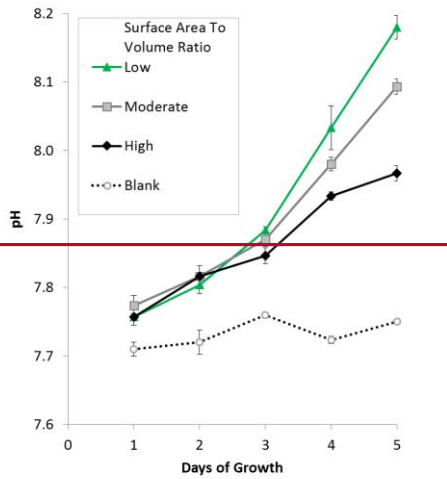
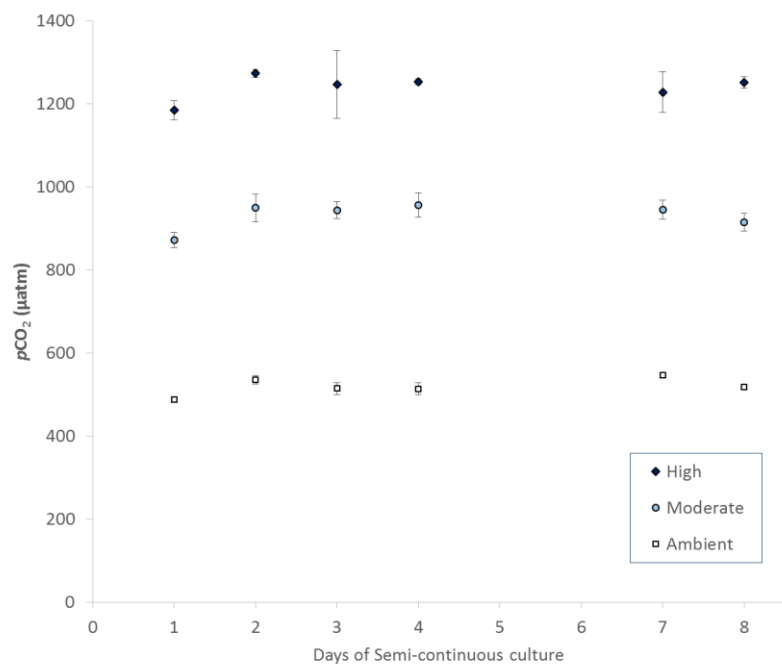

Figure 2: Flasks with high surface area to volume ratios show more evidence of atmospheric equilibration compared to low surface area to volume flasks when biomass and air/water CO₂ gradients are high after several days of growth. Treatments represent triplicate batch cultures of *Emiliana Huxleyi*. Surface area to volume ratios tested are 90 (low), 116 (moderate) and 162 (high) cm² L⁻¹, corresponding to volumes of 900, 700 and 500 ml in a square 1 Liter flask (n=3). Blanks, which do not contain algal cells retain relatively constant pH (total scale). Values are means, error bars are standard deviation.

450



455

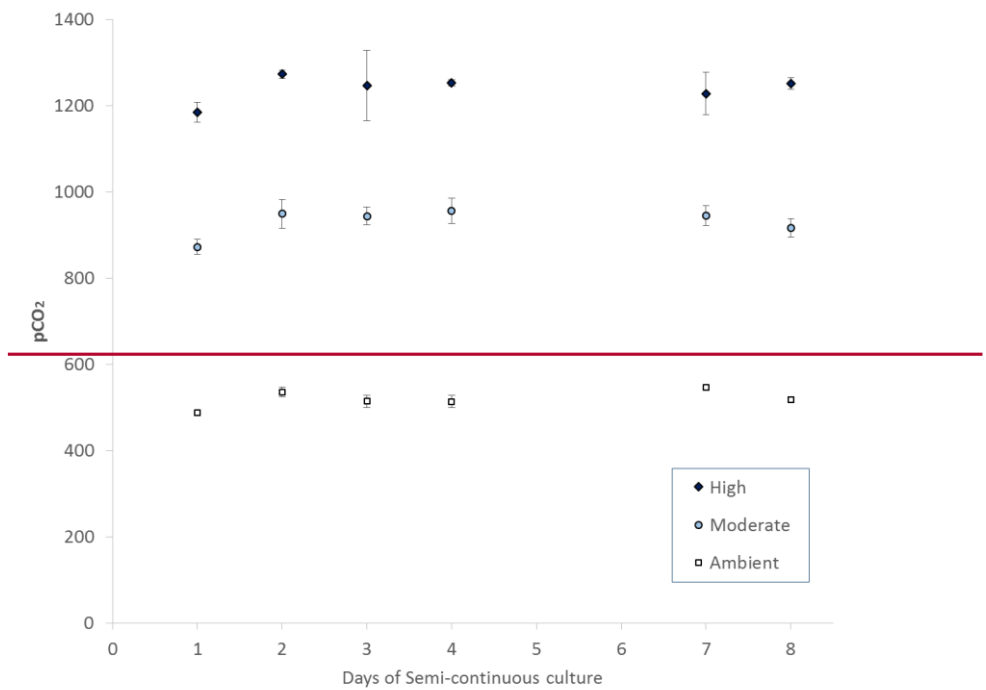
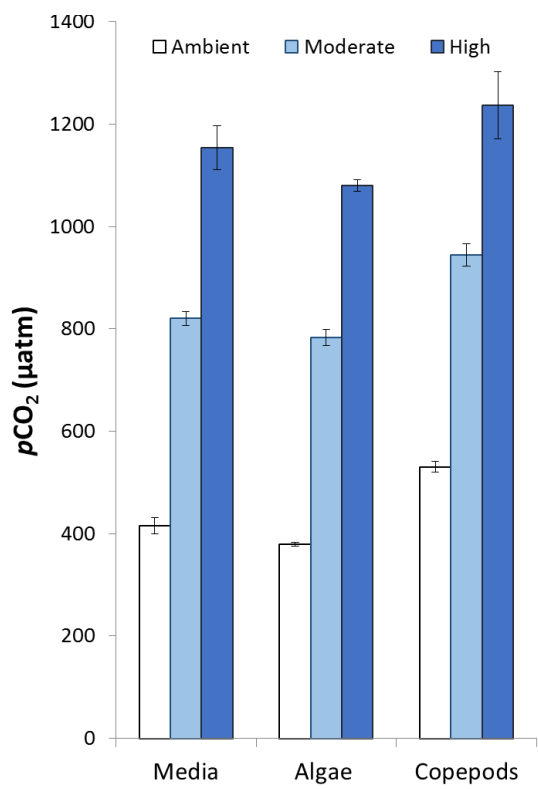
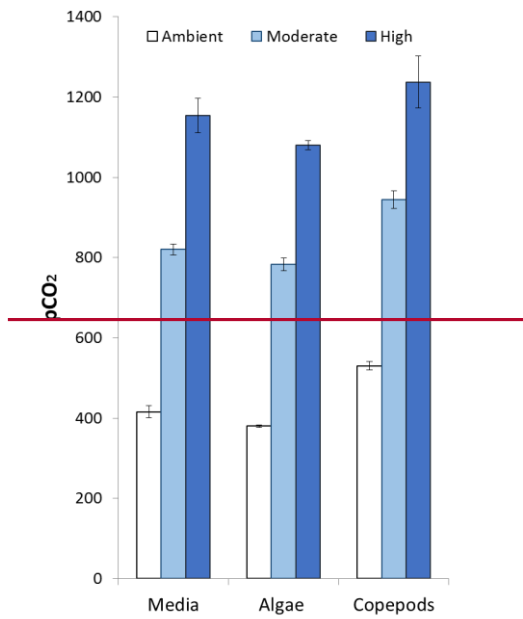

Figure 3 – Maintenance of $p\text{CO}_2$ over time in mixed cultures of the copepod *Calanus pacificus* and its prey *Ditylum brightwellii* (n=3, Experiment 2). Cultures were maintained in atmospheric chambers under semi-continuous culture with artificial atmospheres with no bubbling and media for daily dilutions was bubbled with air at 400 (ambient), 800 (moderate) and 1200 (high) $\mu\text{atm } p\text{CO}_2$. Values are means, error bars are standard deviation.

460





465 Figure 4: System performance as measured by maintenance of $p\text{CO}_2$ in pre-conditioned media, algal cultures (diatom *Dytilum brightwellii*), and mixed cultures of the algae and the copepod *Calanus pacificus* (n=6, Experiment 2). Algae and ~~copepods~~Copepods were under semi-continuous culture with artificial atmospheres and media for daily dilutions was bubbled with air at 400 (ambient), 800 (moderate) and 1200 (high) $\mu\text{atm } p\text{CO}_2$. Values are means, error bars are standard deviation.

470 Table 1: Comparison of daily variability in pH (**total hydrogen ion scale**) in semi-continuous OA studies without direct bubbling. Δ pH is the mean absolute difference between pH before and after dilution (where available). Dilution interval indicates days between dilution of cultures. Ambient conditions are nominally between 380 and 450 $\mu\text{atm CO}_2$. High conditions are nominally between 1000 and 2000 $\mu\text{atm CO}_2$. All studies apart from ACCS experiments are simple semi-continuous cultures with closed conditions between dilutions.

Study	Organism	Dilution Interval (Days)	Δ pH Ambient	Δ pH High
Webb 2016	Coccolithophore	4	0.45	0.55
Hildebrandt 2016	Copepod	4	0.19	0.13
Xu and Gao 2015 ^a	Coccolithophore	3	0.07	0.07
Kurihara 2004	Copepod	2	0.03	0.15
Gao 2009 ^a	Coccolithophore	1	0.08	0.08
Vehmaa 2012	Copepod	1	0.20	0.06
Cripps 2014	Copepod	1	0.03	0.01
ACCS Exp 1^b	Copepod	1	0.09	0.04
ACCS Exp 2	Copepod	1	0.05	0.02
ACCS Exp 3	Copepod	1	0.07	0.02
ACCS Exp 4	Copepod	1	0.02	0.001

475 ^a maximum drift as reported, not specified by treatment

^b75% of difference between of pH of media used to dilute the cultures and pH at end of dilution interval as an estimate of Δ pH when a 75% replacement of volume is used for experiments 1-4.

Formatted Table

480

Table 2: Details of recent experiments using the ACCS. Each experiment includes an algal prey species (listed first) and a copepod (listed second). Algae were maintained in 1 liter bottles, about half full and copepods were cultured in 500 ml dishes. All cultures were maintained either with ~~direct bubbling (active)~~ or semi-continuous culture in atmospheric simulation chambers (passive) or direct bubbling (active). Algal prey cells were added to the copepod cultures twice daily (every 12 hours) to maintain saturating feeding conditions.

Experiment	Species	$p\text{CO}_2$ Control	T (°C)
1	<i>Prorocentrum micans</i>	Passive	12
	<i>Calanus pacificus</i>	Passive	
2	<i>Ditylum brightwellii</i>	Active	12
	<i>Calanus pacificus</i>	Passive	
3	<i>Rhodomonas salina</i>	Active	12
	<i>Acartia hudsonica</i>	Passive	
4	<i>Rhodomonas salina</i>	Active	17
	<i>Acartia hudsonica</i>	Passive	

485

Formatted Table

Formatted: Font: Italic

Detailed Response To Reviewers:

490 Interactive comment on “Technical Note: A minimally-invasive experimental system for pCO₂ manipulation in plankton cultures using passive gas exchange (Atmospheric Carbon Control Simulator)” by Brooke A. Love et al.

We are pleased to provide this record of our response to the reviewer suggestions. They were helpful and relatively simple to address. Thank you for your time in evaluating these changes and your help in getting this manuscript into print. Line numbers here refer to those in the final manuscript, not the marked up version.

495

Anonymous Referee #2

Received and published: 8 March 2017 General comments: The manuscript is well structured and clearly written. This novel system is well thought out and I believe it to be an important contribution to the task of ocean acidification studies. The introductory material presents well the advantages and limitations of various approaches. Also the system is described in a sufficient way. Although, this is the microcosm study, which has various limitations, the authors acknowledge and describe most of its limitations. Despite that, I think there is also one limitation of this study, which should be mentioned. These are the factors which affect the gas transfer velocity, hence gas exchange with the atmosphere. As this is closed system, in reality the gas exchange with atmosphere could be (and most likely is) quite distinct from what it could be observed in microcosms. As in reality it is affected by wind speed, convection etc. , lack of these factors in microcosms may limit the realism of the experiment.

500

505

We appreciate the generally positive response of reviewer two. You make a good point about gas transfer velocity in a closed vessel such as this one. We have added some text addressing this point in the “gas exchange effects” section on lines 158-162

Beside that, also, are ions monitored as well? The ionic strength also affects CO₂. And I think it should also be added, what is the volume of each vessel?

510

We did monitor salinity and that is included in the table summarizing the carbonate chemistry in more detail as requested by reviewer 1. We give the volume of the atmospheric chambers on line 113, so I think you are asking about the vessels used in culturing for the example studies here. We have added on line 120-125 a statement that culture vessel size can vary quite a bit in the system and put in specifics about what vessels we used in the caption to table 2 where experimental details are laid out.

515

I particularly appreciate the possibility of using different, controlled atmospheres. This could be especially useful in stimulating past and/or future ocean acidification. This would be helpful in studies of the carbonate chemistry of seawater under past, present and future conditions, especially under ongoing climate change.

Specific comments: in pCO₂ be p should be italicised

520 *We have made this correction throughout.*

Line 18: Although for me it is clear what OA stands for, I think it should be explained anyway

We replaced the abbreviation with the full term for the abstract here.

Line 129: the lower case of 2 in CO₂ sys. And please explain: CO₂sys is the abbreviation for?

We have made this correction (Line 142)

525 Line 143: -1 should be upper case

We have made this correction - superscript

Line 155: “more than a dozen”: I think it is better to put the actual number of experiments than just the word “dozen”

There have been a number of student experiments and repeated experiments or subsets of long runs etc... so it is hard to put a hard number on this, but I made a reasonable estimate. (Line 172)

530

Line 160, 419: *Emiliana Huxleyi* should be italicised

We have made this correction

Line 167: should be just:” Hoffmann et al (2011).

We have made this correction (Line 184)

535 Fig. 1 All the abbreviations should be explained, for example Sim. Ch. or Dist.

We have made this correction by replacing abbreviated text with the non-abbreviated version in the figure.

Fig. 3, fig. 4: pCO₂ is missing units

We have corrected this.

Supplementary note: Line 23: “minimal pressure”: what is the value of this minimal pressure?

540

This has been altered to read “slowly (about 10 ml/min) because with syringe filtering, although the aim to keep pressure low, we do not measure the pressure applied.

Anonymous Referee #1 Received and published: 4 January 2017

545 General Comments: This is a very interesting and well-written manuscript that describes a sophisticated and novel ocean acidification (OA) simulation system. Of particular interest is the use of CO₂-enriched headspace to compensate for the CO₂ drawdown effects of photosynthetic organisms. In addition, the opportunistic use of fluctuations in carbonate chemistry (caused by water replacement) to mimic diurnal changes in carbonate chemistry in the field is interesting, especially in the context of the ever-increasing demand for more realistic OA simulation systems.

550 The authors acknowledge that the design of this system is vulnerable to the pseudoreplication outlined in Cornwall and Hurd (2015). However, insufficient detail is given on how this can be compensated for during data analysis, e.g. does a ‘nested design’ fully counter these problems? Have the authors considered evaluating the variability caused by ‘Culture Vessel’ as a random effect? This can quantify the independence or non-independence of phytoplankton cultures maintained in the same chamber.

555 We appreciate this clarification. The inclusion of the atmospheric chamber as a random effect is what we meant by a nested design, wherein the atmospheric simulation chamber is “nested” as a variable within each treatment condition. We have made this more clear in the manuscript on lines 252-254.

While this manuscript is very well-written, the overview of the system (Section 2) lacks a straightforward and thorough description of the simulation apparatus. I am still unclear on how large the culture vessels are, how they are physically
560 positioned in the simulation chamber, and how the chambers are maintained from day to day. The introductory passage in Section 2 should be expanded to include a detailed description.

We have included more specific details about the dimensions of the chambers, as well as the volume. (Line 113) and more details about the size and number of culture vessels that were used in these studies. We also added a brief description of daily operation including checking the pCO₂ level in gas streams, physical handling during dilutions and replacement in the chambers.
565

Finally, as this manuscript describes a novel OA simulation system, I expected the authors to include all measurements used in the validation process, i.e. Total Carbon and Total Alkalinity data. The supplementary document provides ample detail on how these measurements were taken, but does not include the data needed to gauge the success of the system. In any case, these measurements should be included in the manuscript of any description of a novel OA simulation system.

570 *Yes, in the interest of brevity we did not include those data, but we are happy to do so and have included a table with the relevant detailed data in table S1.*

Specific Comments Line 24-25: ‘Manipulative OA research has increased dramatically. . .’ Comment: On what timescale?

Good catch. We have added “over the last decade here”.

Lines 41-42: ‘The ACCS is designed to accommodate differing trophic levels and differing levels of desired carbonate control, re-equilibration, or metabolically driven cycling.’ Comment: I recommend that the authors briefly expand on these claims in
575 this passage, allowing the reader to place the system in the context of other acidification apparatus.

We have added a bit more detail to each of these claims - referring to the flexibility in the culture vessels and the ability to manipulate the surface area to volume ratios to influence the gas exchange.

Line 67: In the unpublished data referred to here, what was the control, i.e. the un bubbled culture, that the authors compared
580 with the bubbled culture? Was this part of a validation exercise? If so, please expand on this statement and refer to the validation trial.

*We have changed the wording here to: “We observed possible detrimental effects of bubbling, including reduced growth rates and formation of aggregates during culturing of autotrophic dinoflagellates which were resolved when cells were cultured under passive gas exchange conditions (unpubl. data).” This should indicate that this was an
585 informal observation, not a formal trial. The surface area to volume experiment described elsewhere in the manuscript were part of our validation trials.*

Line 176-177: ‘This level of variability rivals that of some of the most dynamic marine systems.’ Comment: This statement needs an example and citations.

590 *We have added a reference to Hoffman et al (2011) here and list the observed pH ranges in that study for upwelling and estuarine systems.*

Technical Comments Line 55: 'e.g.' is in the middle of the in-text citation. Line 73: 'e.g.' is in the middle of the in-text citation.

These have been corrected

Figure 1: Add an explanation of the abbreviation 'sim.ch.'

Done

595 Table 1: Please specify that pH is reported on the Total Hydrogen Ion Scale.

Done

Figures 3 and 4 are mentioned in the text before Figure 2.

600 *It appears that the reviewer missed the first reference to figure 2 in the gas exchange section. We think that the figures are presented in the correct order.*

Figure 3: Are the error bars SD or SE?

They are SD. This has been added to the caption.

Figure 4: Are the error bars SD or SE?

They are SD. This has been added to the caption.

605

Figure 2: Are the error bars SD or SE?

They are SD. This has been added to the caption.

Line 160: Scientific name (*Emiliana huxleyi*) is not italicised.

Fixed

610 Lines 168-169: There is a formatting error in the citation for Hofmann et al. (2011).

Fixed